

MFS | MECHANICAL FLANGE SPREADERS

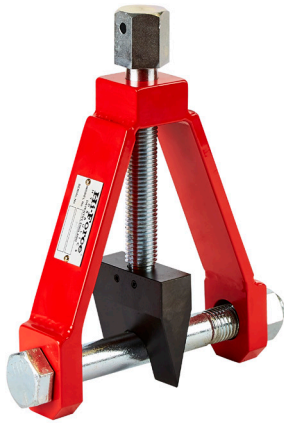

Suitable for bolt diameters up to 31 mm

Maximum spread 231 mm

No external power source required

- ▶ Manually operated mechanical feed screw design
- ▶ Capable of opening flanges up to 2 x 95 mm thickness
- ▶ Economical and safe operation
- ▶ High grade steel construction with high tensile cross bolt
- ▶ Case hardened spreading wedge
- ▶ Compact, portable and easy to use

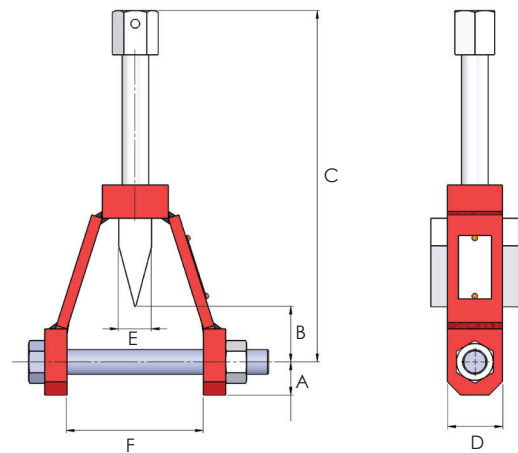

Model number	Pin diameter		Min flange bolt hole diameter	Maximum flange thickness		Weight (kg)	Dimensions (mm)						
	mm	inch		mm	inch		A	B (max)	C (min)	C (max)	D	E	F
MFS16	16	5/8"	17	2 x 22	2 x 7/8"	2.2	25	28	185	232	40	25	70
MFS19	19	3/4"	20	2 x 35	2 x 1 3/8"	2.7	30	50	185	254	50	25	95
MFS22	22	7/8"	23	2 x 47	2 x 1 13/16"	4.1	30	50	247	318	50	30	124
MFS25	25	1"	26	2 x 62	2 x 2 7/16"	6.4	30	85	247	353	50	30	155
MFS28	28	1 1/8"	29	2 x 70	2 x 2 3/4"	8.2	30	80	275	382	60	40	181
MFS31	31	1 1/4"	32	2 x 95	2 x 3 3/4"	9.6	32	84	275	385	60	40	231