

HB500GS270FaPo



Do you work in narrow spaces?
With our slewing cranes, you can pick up loads even next to the crane!

At a glance

LIFTING	
manual	✓
Compact hydraulic system	✗
Hydrobull pump	✓
electric	✗

DRIVING	
manual	✓
Steering handle	✗
FaPo	✓
electric	✗

OPERATING FREQUENCY	
up to 10 times per month	✗
up to 25 times per month	✗
up to 100 times per month	✓
more than 100 times per month	✗

LIFTING CAPACITY WITH HORIZONTAL JIB		
	max. 500 kg	✓
	90 kg at 2457 mm in front of the wheels	✓

Link to www.hydrobull.de

Here, you can find more information incl. videos, photos etc.



These original Hydrobull cranes with slewing function are counterweight cranes with a jib which can be manually slewed right and left. This is particularly advantageous in narrow aisles where the load to be lifted is to the right or left of the aisle and the aisle is too narrow for the complete crane to make a 90 degree turn. The **slewing counterweight** allows it to directly approach loads and machines. All 13 positions are in FRONT of the wheels and, when slewed, laterally in front of the chassis, so that the crane has an extremely clear outreach. The clear outreach and the large lifting height allow the cranes to be used frequently for tool changes and maintenance work (also above machine installations or under the ceiling). The slewing crane was designed to provide a long service life even with frequent use.

👉 LIFTING/LOWERING



Secured to a high-quality galvanised DIN-standard swivel hook with the original **Hydrobull pump with 4 power/lift settings**. The detailed description can be found in our Technical Information Sheet 1.

👉 Driving



Manually supported by the Hydrobull mechanical **driving positioning device, FaPo®** for short. The detailed description can be found in our Technical Information Sheet 1.

👉 SLEWING

The jib can be manually slewed through 270°. For support, the pump lever extension can be attached to a pin on the column and increase the slewing force. The jib can also be locked in the slewed position with a brake latch in a perforated plate.

The special feature of the Hydrobull slewing cranes is that **no supports** are required. **The crane is always mobile and ready for use – even under load.**

👉 JIB

Has 13 setting which can be easily selected via 2two separate galvanised jibs using a socket pin system.

In addition, the jibs are secured with a squeeze-out lock to prevent accidents due to unintentional falling out. A mechanical telescopic jib which is adjustable under load is also available for an extra charge.

👉 PARKING

Is done easily and conveniently by turning a lever mounted on the guard of the FaPo steering wheel. **Manual machines are generally** not equipped with a travel brake.

👉 COUNTERWEIGHT

The crane requires a slewing counterweight. It is made of solid steel material and is attached directly to the column. The counterweight is to be installed on-site and is included in the price. The machine and the counterweight are delivered as two packages. The counterweight must be attached to the column with a suitable lifting aid using bolts and nuts.

👉 OTHER

- Seal kits and other spare parts are available ex stock for both the cylinder and the pump
- Modern, protected design – only from Hydrobull
- Delivery incl. inspection book and operating instructions
- German Product
- Euronorm 2006/42/EC and DGUV68
- **2 Year Warranty**
- Spare parts for older machines on request

Technical Drawings

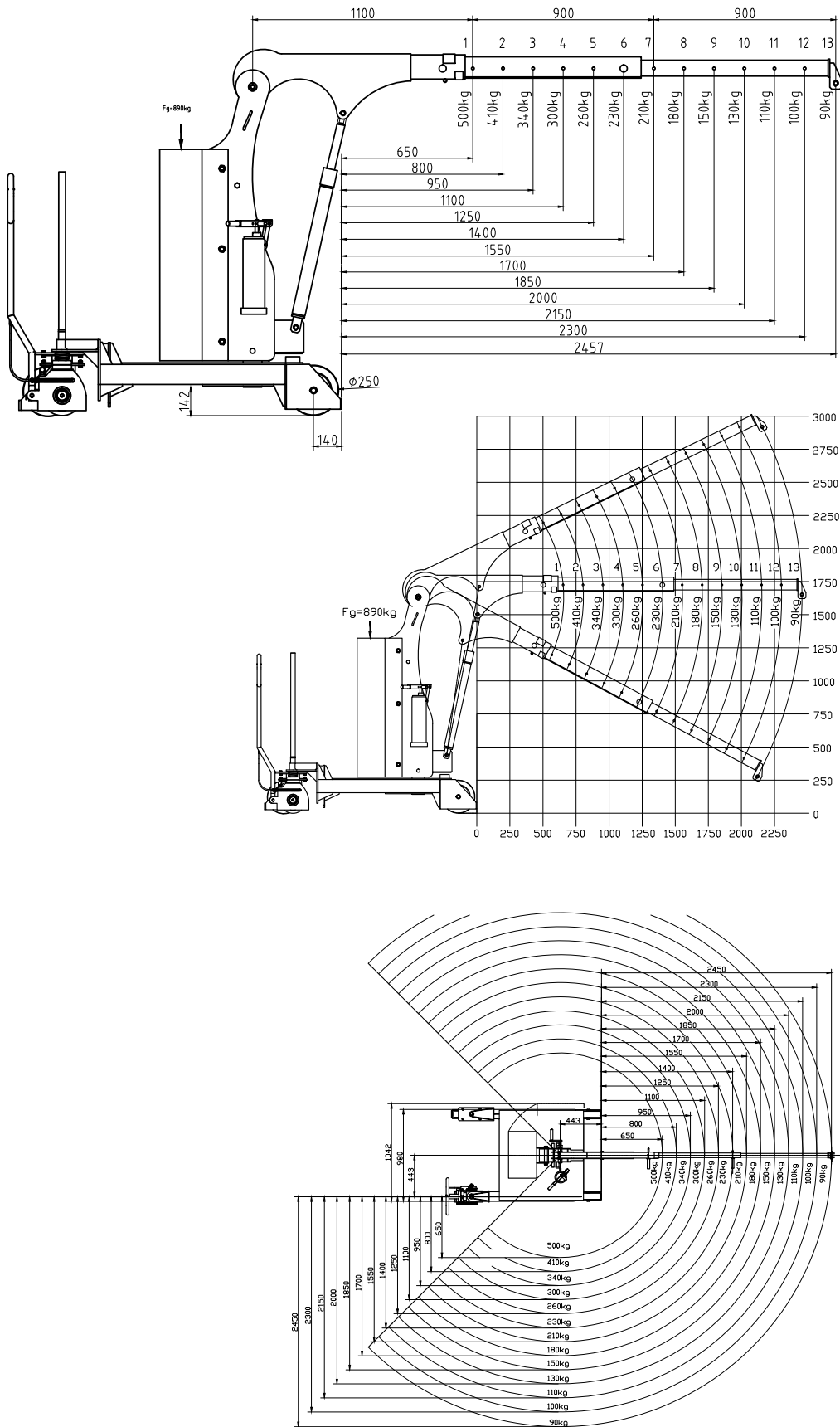

Subject to technical modifications. Data subject to manufacturing tolerances.

Technical specifications

RATIO LIFTING CAPACITY, OUTREACH, LIFTING HEIGHT

Jib Position	Lifting capacity/kg	Load with horizontal jib/mm		Lift height*/mm	
		in front of the hydraulic system approx.	in front of the wheels approx.	min.	max.
1	500	650	650	850	2350
2	410	800	800	750	2450
3	340	950	950	650	2560
4	300	1100	1100	550	2670
5	260	1250	1250	450	2780
6	230	1400	1400	350	2890
7	210	1550	1550	250	3000
8	180	1700	1700	150	3105
9	150	1850	1850	50	3210
10	130	2000	2000		3310
11	110	2150	2150		3410
12	100	2300	2300		3510
13	90	2457	2457		3610

* at hook mouth opening - please refer to the diagram for the reduced outreach

OTHER DETAILS

		min.	max.
Jib length from... to...		1100	2900
Length of wheelbase	mm		1250
Length of chassis incl. wheels	mm		1700
Length incl. inserted lowered jib Pos. 1	mm		2160
approx. aisle width for 90° turn	mm		
Width of chassis external	mm		980
Width of chassis internal	mm		-
Clearance height, jib horizontal	mm		1960
Clearance height, jib lowered	mm		1920
Clearance	mm		-
Hook length approx.	mm		225
Ground clearance	mm		30
Load wheel	mm		3 x 250
Steering wheel	mm		200
Slewing	°		270
Tare weight - for counterweight cranes incl. empty box	kg		630
Required filling weight for counterweight cranes**	kg		890
Batteries			-

** Machine can only be used when installed



Not the right machine? No problem!

Fill out our form on www.hydrobull.de and we will happily produce a custom transport solution for you.