

56-2 Single-edged, grease hydraulic nut splitter 22 mm - 36 mm (70 Nm Nm max. torque)

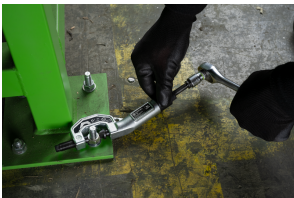

APPLICATION IMAGE



DESCRIPTION

The single-sided, fat-hydraulic nut splitters are used for splitting particularly large, stuck, rusted, or overtightened nuts of quality classes 5, 6, 8, and 10. During this splitting process, the threaded pin remains undamaged. Thanks to the fat hydraulics, only a small amount of force is required. For better ease of use, the nut splitter is slightly angled.

APPLICATION AREA

For blasting particularly large, stuck, rusted or over-torqued nuts of grades 5, 6, 8 and 10

BENEFIT

- Removing the mother is possible without damaging the thread bolt.
- Fat hydraulic ensures a significant reduction in workload.
- Very sharp cutting edges due to facet grinding
- Slightly angled design for better ease of use
- Also suitable for use in pipeline construction and other industries.

OPERATION

- Apply the spindle splitter to the stuck {Anschlagmutter}
- Set the hexagon at the spindle head in motion with a ratchet or an open-end wrench until the nut is split

MASTER DATA

GTIN [EAN]	4021176020551
Country of origin	DE
Case material	Tool steel
Series	56
Net weight [kg]	2,865 kg
Package contents	1 piece
Packaging Act	PAP 21
Global sales capability given	Yes (REACH, RoHS, POP, PROP65, TSCA)

SPARE PARTS

- 56-2-M_Splitter chisel
- 56-2ERS_wear parts set

Single-edged, grease hydraulic nut splitter 22 mm - 36 mm (70 Nm Nm max. torque)

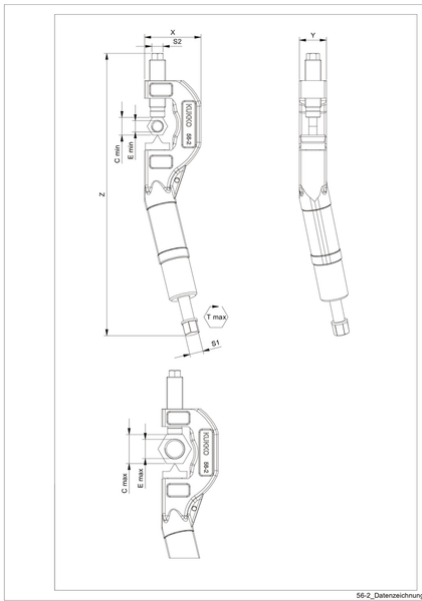

Abbreviation	Attribut	Wert
X	Total width [mm]	70 mm
Y	Total depth [mm]	33 mm
S1	Width across flats [mm]	17 mm
S2	Width across flats [mm]	14 mm
Tmax	Max. torque [Nm]	70 Nm
Z	Total length [mm]	330 mm
Cmin	Width across flats of the nut (min) [mm]	22 mm
Cmax	Width across flats of the nut (max) [mm]	36 mm