

55-1 Single-edged mechanical nut splitter 10 mm - 18 mm



APPLICATION IMAGE



DESCRIPTION

The single-blade mechanical nut splitter is used for splitting stuck, rusted, or over-tightened nuts with a tensile strength of up to 800 N/mm². During this splitting process, the threaded pin remains undamaged. The sharp edge of the chisel, which has a faceted grinding, penetrates deeply into the nut when the spindle is tightened, until the nut is split. In confined environmental conditions where there is only limited space around the nut, the single-blade nut splitter is exactly the right choice.

APPLICATION AREA

For blasting stuck, rusted or over-torqued nuts of grade 6

BENEFIT

- Removing the mother is possible without damaging the thread bolt.
- Pullback Technology guarantees easy retraction of the chisel from the exploded nut.
- Also suitable for use in pipeline construction and other industries

OPERATION

- Set the splitter chisel on the seized nut
- Manually pull the spindle for fixation until the chisel presses against the nut
- Engage the hexagon on the spindle head with a ratchet or open-end wrench until the nut is split
- Unscrew the chisel from the split nut
- If the nut is still not released after the first splitting attempt, the process must be repeated from the other side

MASTER DATA

GTIN [EAN]	4021176020063
Country of origin	DE
Case material	Tool steel
Series	55
Net weight [kg]	0,22 kg
Package contents	1 piece
Packaging Act	PAP 21
Global sales capability given	Yes (REACH, RoHS, POP, PROP65, TSCA)

SPARE PARTS

- 55-1-M_Splitter chisel

Single-edged mechanical nut splitter 10 mm - 18 mm

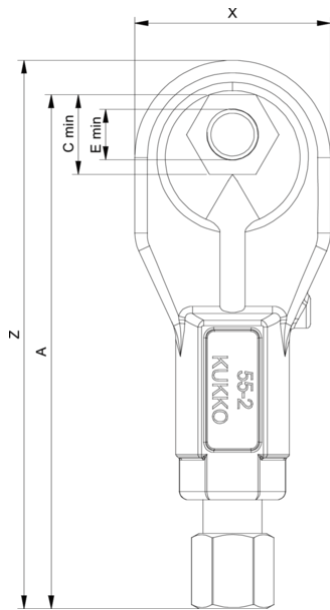

Abbreviation	Attribut	Wert
X	Total width [mm]	31,5 mm
Y	Total depth [mm]	19 mm
S1	Width across flats [mm]	17 mm
Z	Total length [mm]	94 mm
Cmin	Width across flats of the nut (min) [mm]	10 mm
Cmax	Width across flats of the nut (max) [mm]	18 mm
A	Length from spindle head to contact surface [mm]	89 mm

Abbreviation	Attribut	Wert
X	Total width [mm]	31,5 mm
Y	Total depth [mm]	19 mm
S1	Width across flats [mm]	17 mm
Z	Total length [mm]	94 mm
Cmin	Width across flats of the nut (min) [mm]	10 mm
Cmax	Width across flats of the nut (max) [mm]	18 mm
A	Length from spindle head to contact surface [mm]	89 mm