

# 18-2 Puller, up to spread, 260 mm reach M14x1,5



## APPLICATION IMAGE



## DESCRIPTION

The pullers of series 18 are used in conjunction with the separating devices of series 15 and 17 for pulling flat-lying or thin-walled parts in craft, industry, and workshops when there is not enough space for jaws. The separating-pulling process is capable of initially separating those parts gently before they can be externally pulled off.

## APPLICATION AREA

Together with the cut-off devices of series 15 and 17 for the removal of flat or thin-walled parts

## BENEFIT

- By screwing the separator and puller device, the highest stability when pulling is ensured.
- If the separating jaws are screwed into the clamping device the other way around, the support surface is enlarged and pulled off more gently.
- Due to its simple design, special separating devices can also be easily created in-house for the series 18.

## OPERATION

- Press the sharp edges of the separator behind the part
- Tighten the separating jaws evenly by adjusting the nuts on the side bolts of the separator and ensure that the separating blades sit flush under the part being removed
- Thread the tension bolt of the extraction device fully into the threaded holes of the separator
- Hold the separator firmly and carefully pull the relevant part off securely by tightening the clamping nut

## MASTER DATA

GTIN [EAN]	4021176075759
Country of origin	DE
Case material	Tool steel
Series	18
Net weight [kg]	3,245 kg
Package contents	1 piece
Packaging Act	PAP 21
Global sales capability given	Yes (REACH, RoHS, POP, PROP65, TSCA)

## SPARE PARTS

- 018275\_Side screw
- 18-2-T\_Crossbar
- 621170\_Mechanical spindle
- 672152\_Socket nut G1/2 - Sw32 for 18-2

# Puller, up to spread, 260 mm reach M14x1,5

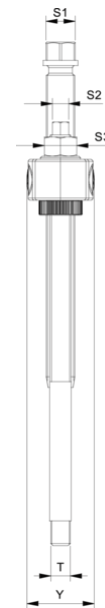
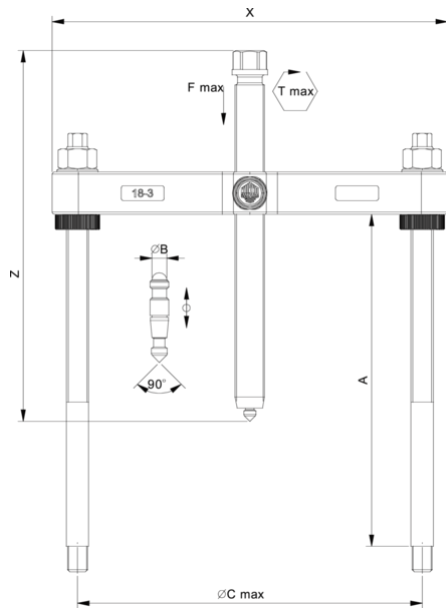

Abbreviation	Attribut	Wert
X	Total width [mm]	282 mm
Y	Total depth [mm]	50 mm
S1	Width across flats [mm]	22 mm
Tmax	Max. torque [Nm]	120 Nm
Fmax	Max. tractive force [t]	7 t
Fmax	Max. tensile force [kN]	70 kN
A	Clamping depth [mm]	260 mm
T	Mounting thread for separator [nominal dimension]	M14x1,5
S2	Width across flats [mm]	12 mm
S3	Width across flats tension bolt nut [mm]	24 mm
S4	Width across flats (hydraulic) [mm]	32

Abbreviation	Attribut	Wert
X	Total width [mm]	282 mm
Y	Total depth [mm]	50 mm
S1	Width across flats [mm]	22 mm
Tmax	Max. torque [Nm]	120 Nm
Fmax	Max. tractive force [t]	7 t
Fmax	Max. tensile force [kN]	70 kN
A	Clamping depth [mm]	260 mm
T	Mounting thread for separator [nominal dimension]	M14x1,5
S2	Width across flats [mm]	12 mm
S3	Width across flats tension bolt nut [mm]	24 mm
S4	Width across flats (hydraulic) [mm]	32