

221-G Internal extractor with sliding hammer, up to 180 mm spread, with 1.7 kg impact weight



APPLICATION IMAGE



DESCRIPTION

The internal extractors with sliding hammer of the series 221 are used for pulling and internal extraction of ball bearings, roller bearings, inner rings, and other flush-mounted parts in craftsmanship, workshops, and industries when there is not enough space for puller jaws. The internal extractor is a purpose-driven model with a large clamping range, which allows for contactless and gentle extraction of, for example, internal bearings due to its design. With the built-in sliding hammer, it not only saves space but also has a strong impact effect, which can securely extract even stuck parts.

APPLICATION AREA

For extracting and internally extracting ball bearings, roller bearings, inner rings and other flush-fitting parts

BENEFIT

- Especially suitable for tight spaces where counter stays or puller devices cannot be installed due to lack of space.
- The built-in sliding hammer means that no support surface is required for this internal extractor.
- The shape of the sliding piece allows for a high impact weight of the sliding hammer with simple application.
- The internal stop point prevents pinching and ensures a safe working process.

OPERATION

- Attach internal extractor to the component to be extracted and insert it into the bore
- Operate the spindle to grip the component to be extracted
- Use sliding hammer with striking motion to pull out the bearings

MASTER DATA

GTIN [EAN]	4021176175824
Country of origin	DE
Case material	Tool steel
Series	221-G
Net weight [kg]	4,4 kg
Package contents	1 piece
Packaging Act	PAP 21
Global sales capability given	Yes (REACH, RoHS, POP, PROP65, TSCA)

Internal extractor with sliding hammer, up to 180 mm spread, with 1.7 kg impact weight

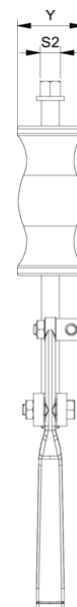
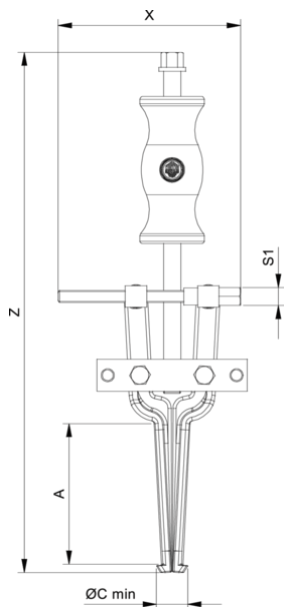

Abbreviation	Attribut	Wert
S1	Width across flats [mm]	17 mm
J	Hook base width (claw width J) [mm]	24 mm
O	Hook base depth usable (claw depth usable O) [mm]	5 mm
H	Total hook root depth (total claw depth H) [mm]	14 mm
L	Total claw thickness (L+1mm) (claw distance to base surface) [mm]	6 mm
Emin	Span inside pull-out (min.) [mm]	30 mm
Emax	Span inside pull-out (max.) [mm]	180 mm
Z	Total length [mm]	490 mm
S1	Width across flats stop nut [mm]	19 mm
A	Impact distance [mm]	250 mm

Abbreviation	Attribut	Wert
S1	Width across flats [mm]	17 mm
J	Hook base width (claw width J) [mm]	24 mm
O	Hook base depth usable (claw depth usable O) [mm]	5 mm
H	Total hook root depth (total claw depth H) [mm]	14 mm
L	Total claw thickness (L+1mm) (claw distance to base surface) [mm]	6 mm
Emin	Span inside pull-out (min.) [mm]	30 mm
Emax	Span inside pull-out (max.) [mm]	180 mm
Z	Total length [mm]	490 mm
S1	Width across flats stop nut [mm]	19 mm
A	Impact distance [mm]	250 mm

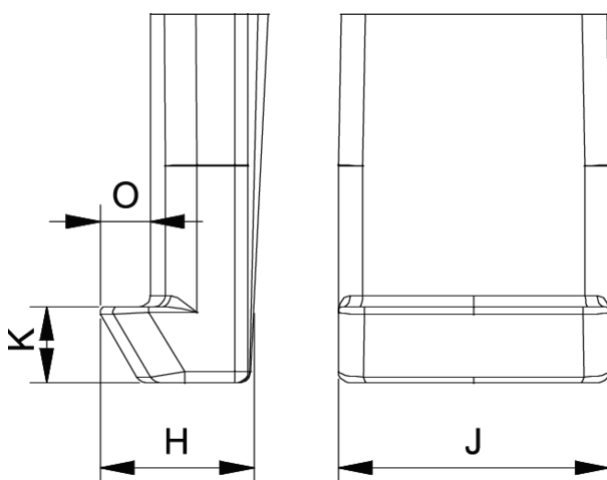

Abbreviation	Attribut	Wert
--------------	----------	------

S1	Width across flats [mm]	17 mm
J	Hook base width (claw width J) [mm]	24 mm
O	Hook base depth usable (claw depth usable O) [mm]	5 mm
H	Total hook root depth (total claw depth H) [mm]	14 mm
L	Total claw thickness (L+1mm) (claw distance to base surface) [mm]	6 mm
Emin	Span inside pull-out (min.) [mm]	30 mm
Emax	Span inside pull-out (max.) [mm]	180 mm
Z	Total length [mm]	490 mm
S1	Width across flats stop nut [mm]	19 mm
A	Impact distance [mm]	250 mm

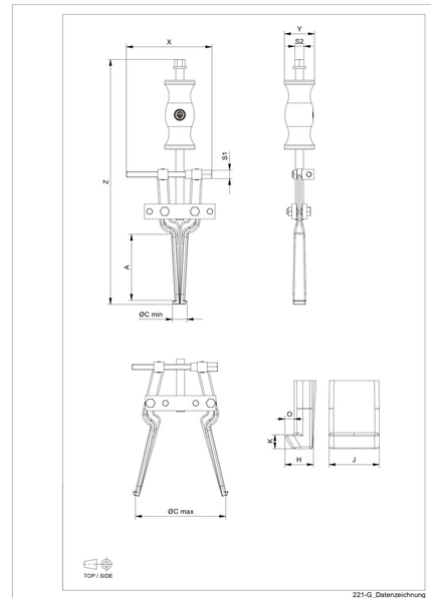

Abbreviation	Attribut	Wert
S1	Width across flats [mm]	17 mm
J	Hook base width (claw width J) [mm]	24 mm
O	Hook base depth usable (claw depth usable O) [mm]	5 mm
H	Total hook root depth (total claw depth H) [mm]	14 mm
L	Total claw thickness (L+1mm) (claw distance to base surface) [mm]	6 mm
Emin	Span inside pull-out (min.) [mm]	30 mm
Emax	Span inside pull-out (max.) [mm]	180 mm
Z	Total length [mm]	490 mm
S1	Width across flats stop nut [mm]	19 mm
A	Impact distance [mm]	250 mm