

22-3 Counter stay, up to 180 mm spread, 280 mm reach



APPLICATION IMAGE



DESCRIPTION

The supports of the series 22 are used together with the internal extractors of the series 21 in crafts, industry, and workshops. Supports are particularly well suited for large cylinder bushings and ball bearings, etc., thanks to the ribbed shape of the support feet, and ensure a firm stand during extraction. In this way, the gentle extraction of internal components is improved. Unlike a sliding hammer, a counter stay allows for more precise work with greater force.

APPLICATION AREA

Together with internal extractors of series 21

BENEFIT

- Sizes from 21-2 are particularly low-friction due to integrated pressure bearings in the form.
- The friction resistance of the counter nut is minimized by an integrated pressure bearing.

OPERATION

- Determine the internal diameter of the Ball bearing and select a suitable Internal extractor
- Insert the Internal extractor into the bore and tighten the clamping nut
- Support the Counter stay on the housing and screw it onto the wedge spindle of the Internal extractor
- Hold the handle of the Counterstays and pull out the bearing safely by tightening the hexagon nut
- Retighten the clamping nut when pulling out

MASTER DATA

| | |
|-------------------------------|--------------------------------------|
| GTIN [EAN] | 4021176012488 |
| Country of origin | DE |
| Case material | Tool steel |
| Series | 22 |
| Net weight [kg] | 4 kg |
| Package contents | 1 piece |
| Packaging Act | PAP 21 |
| Global sales capability given | Yes (REACH, RoHS, POP, PROP65, TSCA) |

SPARE PARTS

- 022-306_Replacement spindle
- 22-3-1-P_2 jaws (pair)
- 22-3-T_Crossbar

Counter stay, up to 180 mm spread, 280 mm reach

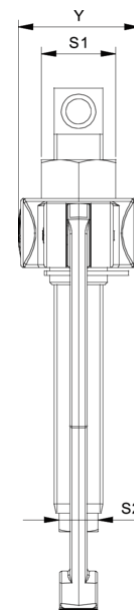
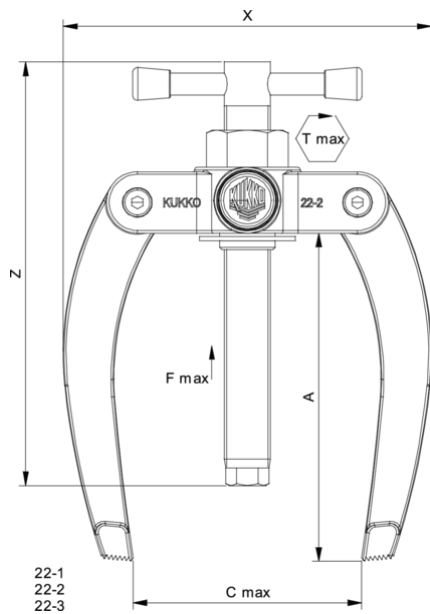

| Abbreviation | Attribut | Wert |
|--------------|--|-------------------|
| X | Total width [mm] | 260 mm |
| Y | Total depth [mm] | 51 mm |
| S1 | Width across flats [mm] | 32 mm |
| Fmax | Max. tractive force [t] | 5 t |
| Fmax | Max. tensile force [kN] | 50 kN |
| A | Clamping depth [mm] | 280 mm |
| T1 | External thread of the spindle [nominal dimension] | G 1/2 |
| T2 | Internal thread of the spindle [nominal dimension] | G 1/2, 15-16 G |

| Abbreviation | Attribut | Wert |
|--------------|--|-------------------|
| X | Total width [mm] | 260 mm |
| Y | Total depth [mm] | 51 mm |
| S1 | Width across flats [mm] | 32 mm |
| Fmax | Max. tractive force [t] | 5 t |
| Fmax | Max. tensile force [kN] | 50 kN |
| A | Clamping depth [mm] | 280 mm |
| T1 | External thread of the spindle [nominal dimension] | G 1/2 |
| T2 | Internal thread of the spindle [nominal dimension] | G 1/2, 15-16 G |

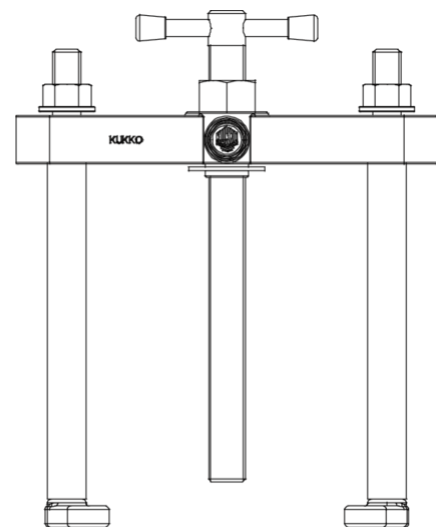
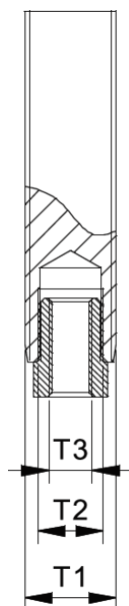

22-4
22-5

| Abbreviation | Attribut | Wert |
|--------------|----------|------|
|--------------|----------|------|

| Abbreviation | Attribut | Wert |
|--------------|----------|------|
|--------------|----------|------|

| | | |
|------|--|-------------------|
| X | Total width [mm] | 260 mm |
| Y | Total depth [mm] | 51 mm |
| S1 | Width across flats [mm] | 32 mm |
| Fmax | Max. tractive force [t] | 5 t |
| Fmax | Max. tensile force [kN] | 50 kN |
| A | Clamping depth [mm] | 280 mm |
| T1 | External thread of the spindle [nominal dimension] | G 1/2 |
| T2 | Internal thread of the spindle [nominal dimension] | G 1/2, 15-16 G |

| | | |
|------|--|-------------------|
| X | Total width [mm] | 260 mm |
| Y | Total depth [mm] | 51 mm |
| S1 | Width across flats [mm] | 32 mm |
| Fmax | Max. tractive force [t] | 5 t |
| Fmax | Max. tensile force [kN] | 50 kN |
| A | Clamping depth [mm] | 280 mm |
| T1 | External thread of the spindle [nominal dimension] | G 1/2 |
| T2 | Internal thread of the spindle [nominal dimension] | G 1/2, 15-16 G |