

# 210-2 2-jaw bearing separator "Cobra" with adjustable reach, side clamp, up to 135 mm spread, 270 mm reach



APPLICATION IMAGE



DETAIL IMAGE

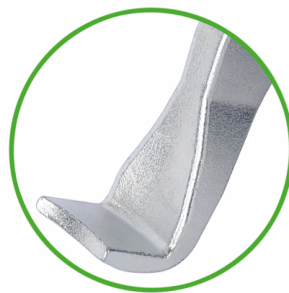

## DESCRIPTION

The 2-jaw bearing separator "Cobra" with adjustable reach and side clamp is used for pulling off flat-mounted bearings, gear wheels, and discs in all common sizes for crafts, workshops, and industry. This allows for the loosening of any component that sits on a shaft and is freely accessible from the outside. The puller jaws are rotatable by 180° and can be applied on both sides. One side has standard puller claws, while the other side features special separator claws. Thanks to the multiple drill holes in the puller jaws, different reaches can be set for flexible working. The side clamp increases the pressure of the puller jaws manifold and thus prevents the puller from slipping.

## APPLICATION AREA

For pulling off bearings, gear rims and pulleys that are lying flat

## BENEFIT

- Adjustable and 180° rotatable jaws for individual adjustment of the reach due to multiple drilling in the jaws.
- Puller jaws with different support surfaces for flexible work
- The side clamp ensures that the puller jaws are pressed particularly tightly against the part to be pulled.
- Double force application from above and sideways guarantees 100% secure grip
- Anti-slip safety (spindle neck) at the spindle head for safe working with wrench.
- Spindle outlet to protect the thread

## OPERATION

- Position the puller jaws from the outside onto the part to be pulled off
- Slide the claws or separator claws under the component
- Tighten the side clamp for stability support
- Manually pull the spindle to secure
- Move the hexagon on the spindle head with a ratchet or a ring spanner until the component is loosened

## MASTER DATA

GTIN [EAN]	4021176030468
Country of origin	DE
Case material	Tool steel
Series	210
Net weight [kg]	4,325 kg
Package contents	1 piece
Packaging Act	PAP 21
Global sales capability given	Yes (REACH, RoHS, POP, PROP65, TSCA)

## SPARE PARTS

- 204-3-T\_Crossbar
- 204201\_clamp complete
- 210-2-270-P\_2 puller (pair)
- 210201\_Clamp complete
- 623325\_Mechanical precision spindle

# 2-jaw bearing seperator "Cobra" with adjustable reach, side clamp, up to 135 mm spread, 270 mm reach

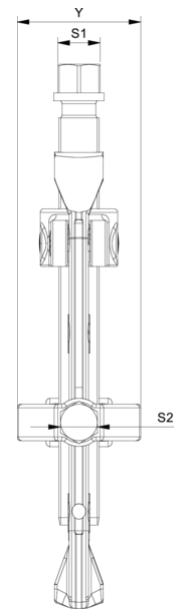
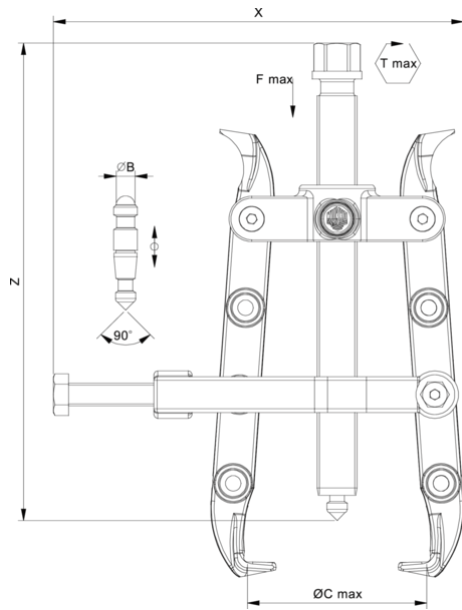

Abbreviation	Attribut	Wert
X	Total width [mm]	320 mm
Y	Total depth [mm]	95 mm
Z	Total height [mm]	330 mm
A	Clamping depth outside pull-off [mm]	270 mm
S1	Width across flats [mm]	24 mm
Cmin	Span outside pull-off (min.) [mm]	20 mm
Cmax	Span outside pull-off (max.) [mm]	135 mm
K	Hook root thickness at the tip (claw thickness K) [mm]	1,5 mm
J	Hook base width (claw width J) [mm]	25 mm
O	Hook base depth usable (claw depth usable O) [mm]	15 mm
H	Total hook root depth (total claw depth H) [mm]	36 mm
L	Total claw thickness (L+1mm) (claw distance to base surface) [mm]	1,5 mm
Tmax	Max. torque [Nm]	140 Nm
Fmax	Max. tractive force [t]	8 t
Fmax	Max. tensile force [kN]	80 kN

Abbreviation	Attribut	Wert
X	Total width [mm]	320 mm
Y	Total depth [mm]	95 mm
Z	Total height [mm]	330 mm
A	Clamping depth outside pull-off [mm]	270 mm
S1	Width across flats [mm]	24 mm
Cmin	Span outside pull-off (min.) [mm]	20 mm
Cmax	Span outside pull-off (max.) [mm]	135 mm
K	Hook root thickness at the tip (claw thickness K) [mm]	1,5 mm
J	Hook base width (claw width J) [mm]	25 mm
O	Hook base depth usable (claw depth usable O) [mm]	15 mm
H	Total hook root depth (total claw depth H) [mm]	36 mm
L	Total claw thickness (L+1mm) (claw distance to base surface) [mm]	1,5 mm
Tmax	Max. torque [Nm]	140 Nm
Fmax	Max. tractive force [t]	8 t
Fmax	Max. tensile force [kN]	80 kN

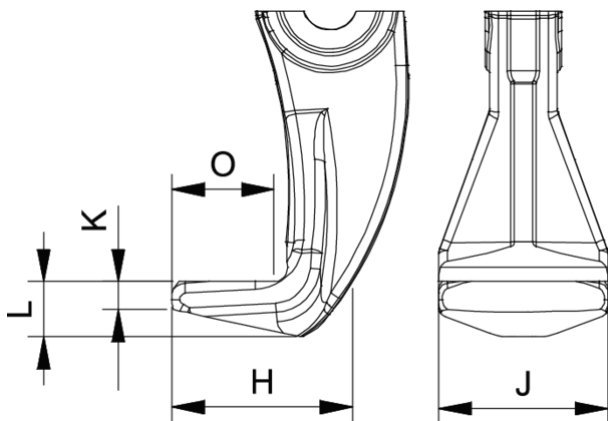

Abbreviation	Attribut	Wert
--------------	----------	------

X	Total width [mm]	320 mm
Y	Total depth [mm]	95 mm
Z	Total height [mm]	330 mm
A	Clamping depth outside pull-off [mm]	270 mm
S1	Width across flats [mm]	24 mm
Cmin	Span outside pull-off (min.) [mm]	20 mm
Cmax	Span outside pull-off (max.) [mm]	135 mm
K	Hook root thickness at the tip (claw thickness K) [mm]	1,5 mm
J	Hook base width (claw width J) [mm]	25 mm
O	Hook base depth usable (claw depth usable O) [mm]	15 mm
H	Total hook root depth (total claw depth H) [mm]	36 mm
L	Total claw thickness (L+1mm) (claw distance to base surface) [mm]	1,5 mm
Tmax	Max. torque [Nm]	140 Nm
Fmax	Max. tractive force [t]	8 t
Fmax	Max. tensile force [kN]	80 kN

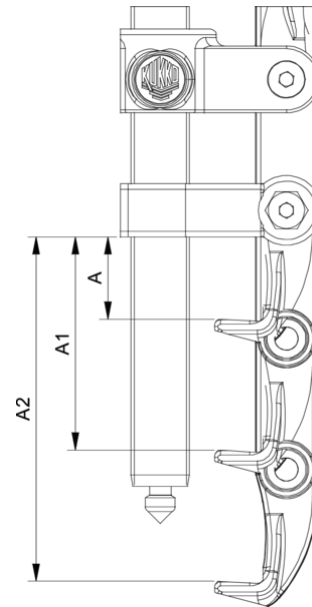

Abbreviation	Attribut	Wert
X	Total width [mm]	320 mm
Y	Total depth [mm]	95 mm
Z	Total height [mm]	330 mm
A	Clamping depth outside pull-off [mm]	270 mm
S1	Width across flats [mm]	24 mm
Cmin	Span outside pull-off (min.) [mm]	20 mm
Cmax	Span outside pull-off (max.) [mm]	135 mm
K	Hook root thickness at the tip (claw thickness K) [mm]	1,5 mm
J	Hook base width (claw width J) [mm]	25 mm
O	Hook base depth usable (claw depth usable O) [mm]	15 mm
H	Total hook root depth (total claw depth H) [mm]	36 mm
L	Total claw thickness (L+1mm) (claw distance to base surface) [mm]	1,5 mm
Tmax	Max. torque [Nm]	140 Nm
Fmax	Max. tractive force [t]	8 t
Fmax	Max. tensile force [kN]	80 kN

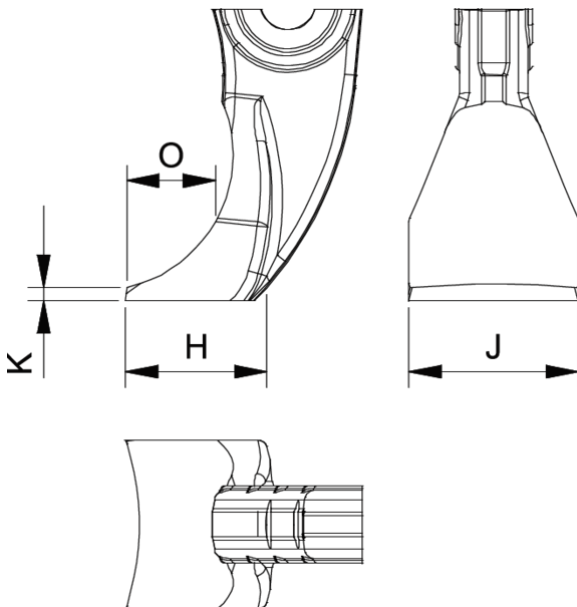

Abbreviation	Attribut	Wert
X	Total width [mm]	320 mm
Y	Total depth [mm]	95 mm
Z	Total height [mm]	330 mm
A	Clamping depth outside pull-off [mm]	270 mm
S1	Width across flats [mm]	24 mm
Cmin	Span outside pull-off (min.) [mm]	20 mm
Cmax	Span outside pull-off (max.) [mm]	135 mm
K	Hook root thickness at the tip (claw thickness K) [mm]	1,5 mm

J	Hook base width (claw width J) [mm]	25 mm
O	Hook base depth usable (claw depth usable O) [mm]	15 mm
H	Total hook root depth (total claw depth H) [mm]	36 mm
L	Total claw thickness (L+1mm) (claw distance to base surface) [mm]	1,5 mm
Tmax	Max. torque [Nm]	140 Nm
Fmax	Max. tractive force [t]	8 t
Fmax	Max. tensile force [kN]	80 kN