

# 202-0 3-jaw tab puller with oscillating, reversible jaws, up to 100 mm spread, 75 mm reach

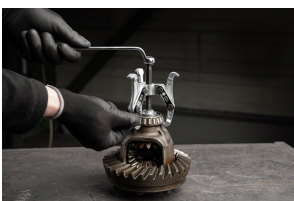

APPLICATION IMAGE



DETAIL IMAGE



## DESCRIPTION

The 3-jaw puller with oscillating and reversible jaws is used for centralized extraction of bearings, gears, and discs in all common sizes for crafts, workshops, and industry. This allows the loosening of any component that sits on a shaft and is freely accessible from the outside. The oscillating jaws with adjustable reach can be applied on both sides. Depending on the design, the claw shape varies. The 3-jawed design ensures even load distribution and a particularly safe grip on the part being extracted.

## APPLICATION AREA

For centric extraction of bearings, gears and pulleys

## BENEFIT

- Adjustable and 180° rotatable puller jaws for individual adjustment of the reach.
- Oscillating puller jaws offer a variety of adjustment options
- Pulling jaws with different claw shapes for flexible working.
- Claw end with slot provides support for screw for additional support when pulling off
- 3-jaw design ensures an even distribution of force and allows for greater pulling forces.
- Secure mounting of the spindle through the rotatable spindle tip on both smooth surfaces and in centering (Switch Technology)
- Anti-slip safety (spindle neck) at the spindle head for safe working with a wrench.
- Spindle outlet for thread protection

## OPERATION

- Position the puller jaws from the outside onto the part to be removed
- Swing the jaws under the component
- Manually pull the spindle to fix it in place
- Use a ratchet or a ring spanner to turn the hexagon at the spindle head until the component is loosened

## MASTER DATA

GTIN [EAN]	4021176027093
Country of origin	DE
Case material	Tool steel
Series	202
Net weight [kg]	0,59 kg
Package contents	1 piece
Packaging Act	PAP 21
Global sales capability given	Yes (REACH, RoHS, POP, PROP65, TSCA)

## SPARE PARTS

- 202-0-75-S\_3 jaws (set)
- 202-0-T\_Crossbar
- 612080\_Mechanical spindle

# 3-jaw tab puller with oscillating, reversible jaws, up to 100 mm spread, 75 mm reach

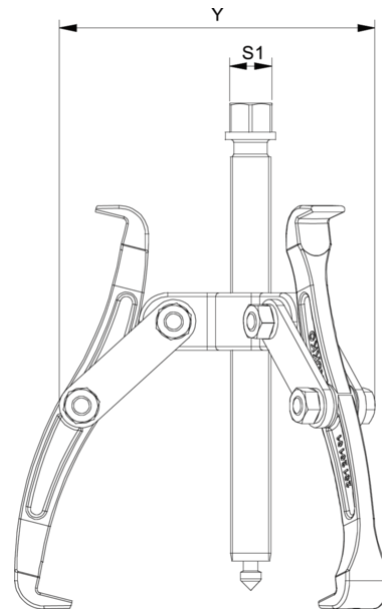
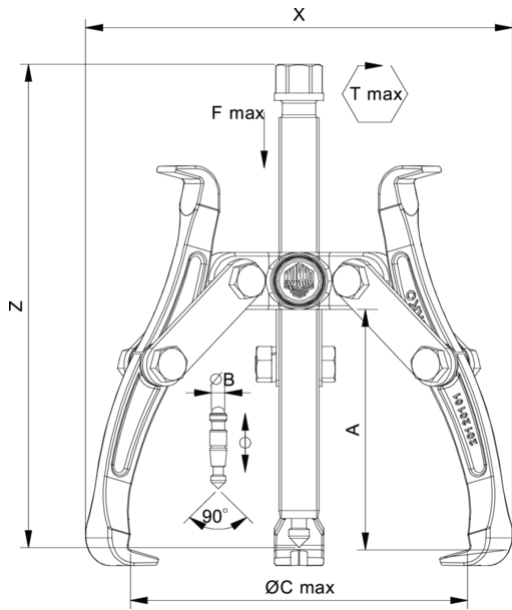

Abbreviation	Attribut	Wert
X	Total width [mm]	112 mm
Y	Total depth [mm]	112 mm
Z	Total height [mm]	105 mm
A	Clamping depth outside pull-off [mm]	75 mm
S1	Width across flats [mm]	13 mm
Cmin	Span outside pull-off (min.) [mm]	0 mm
Cmax	Span outside pull-off (max.) [mm]	100 mm
K	Hook root thickness at the tip (claw thickness K) [mm]	3 mm
J	Hook base width (claw width J) [mm]	11 mm
O	Hook base depth usable (claw depth usable O) [mm]	8 mm
H	Total hook root depth (total claw depth H) [mm]	14 mm
L	Total claw thickness (L+1mm) (claw distance to base surface) [mm]	6 mm
Emin	Span inside pull-out (min.) [mm]	45 mm
Tmax	Max. torque [Nm]	25 Nm
Fmax	Max. tractive force [t]	1.5 t
Fmax	Max. tensile force [kN]	15 kN

Abbreviation	Attribut	Wert
X	Total width [mm]	112 mm
Y	Total depth [mm]	112 mm
Z	Total height [mm]	105 mm
A	Clamping depth outside pull-off [mm]	75 mm
S1	Width across flats [mm]	13 mm
Cmin	Span outside pull-off (min.) [mm]	0 mm
Cmax	Span outside pull-off (max.) [mm]	100 mm
K	Hook root thickness at the tip (claw thickness K) [mm]	3 mm
J	Hook base width (claw width J) [mm]	11 mm
O	Hook base depth usable (claw depth usable O) [mm]	8 mm
H	Total hook root depth (total claw depth H) [mm]	14 mm
L	Total claw thickness (L+1mm) (claw distance to base surface) [mm]	6 mm
Emin	Span inside pull-out (min.) [mm]	45 mm
Tmax	Max. torque [Nm]	25 Nm
Fmax	Max. tractive force [t]	1.5 t
Fmax	Max. tensile force [kN]	15 kN

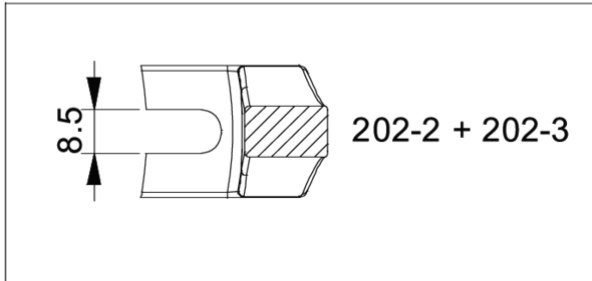
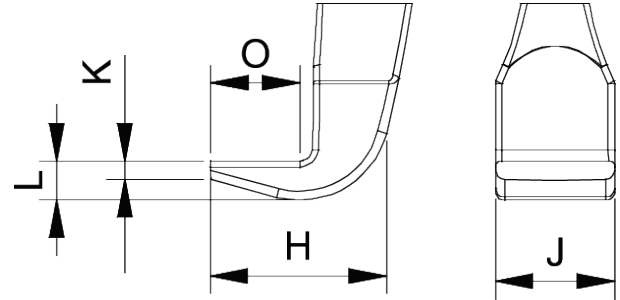
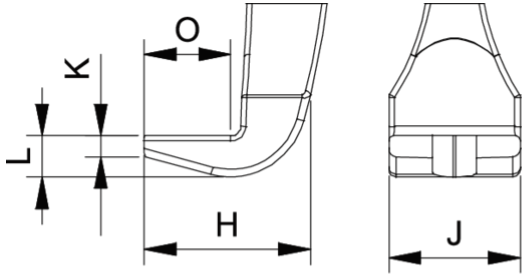

Abbreviation	Attribut	Wert
X	Total width [mm]	112 mm
Y	Total depth [mm]	112 mm
Z	Total height [mm]	105 mm
A	Clamping depth outside pull-off [mm]	75 mm
S1	Width across flats [mm]	13 mm
Cmin	Span outside pull-off (min.) [mm]	0 mm
Cmax	Span outside pull-off (max.) [mm]	100 mm
K	Hook root thickness at the tip (claw thickness K) [mm]	3 mm
J	Hook base width (claw width J) [mm]	11 mm
O	Hook base depth usable (claw depth usable O) [mm]	8 mm
H	Total hook root depth (total claw depth H) [mm]	14 mm
L	Total claw thickness (L+1mm) (claw distance to base surface) [mm]	6 mm
Emin	Span inside pull-out (min.) [mm]	45 mm
Tmax	Max. torque [Nm]	25 Nm
Fmax	Max. tractive force [t]	1.5 t
Fmax	Max. tensile force [kN]	15 kN

Abbreviation	Attribut	Wert
X	Total width [mm]	112 mm
Y	Total depth [mm]	112 mm
Z	Total height [mm]	105 mm
A	Clamping depth outside pull-off [mm]	75 mm
S1	Width across flats [mm]	13 mm
Cmin	Span outside pull-off (min.) [mm]	0 mm
Cmax	Span outside pull-off (max.) [mm]	100 mm
K	Hook root thickness at the tip (claw thickness K) [mm]	3 mm
J	Hook base width (claw width J) [mm]	11 mm
O	Hook base depth usable (claw depth usable O) [mm]	8 mm
H	Total hook root depth (total claw depth H) [mm]	14 mm
L	Total claw thickness (L+1mm) (claw distance to base surface) [mm]	6 mm
Emin	Span inside pull-out (min.) [mm]	45 mm
Tmax	Max. torque [Nm]	25 Nm
Fmax	Max. tractive force [t]	1.5 t
Fmax	Max. tensile force [kN]	15 kN