

483-4 3-jaw puller with force-amplifying, self-centering, tensioning jaws, up to 200 mm spread, 200 mm reach



DETAIL IMAGE



DESCRIPTION

The handy 3-jaw puller with force-amplifying, self-centering, and straining jaws is used for pulling bearings, gears, and discs from tight and hard-to-reach spaces. This allows you to loosen any component that sits on a shaft and is freely accessible from the outside. The integrated force amplification with spring mechanism increases the clamping force proportionally to the pulling force. Tightening the spindle automatically centers the jaws. The 3-jaw design guarantees even load distribution and thus ensures a particularly secure grip on the part being pulled.

APPLICATION AREA

For extracting bearings, gears and pulleys for narrow and poorly accessible gaps

BENEFIT

- Self-centering of the jaws through manual tightening of the spindle (Autogrip Technology)
- The slim design of the jaws enables access to difficult-to-reach areas.
- 3-jaw ensures an even distribution of force and allows for greater pulling forces.
- Anti-slip safety (spindle neck) at the spindle head for safe working with a wrench.
- The thread shape allows for quick tightening of the spindle, as fewer rotations are required.
- Hexagon on the spindle is suitable for operation with powered tools.

OPERATION

- Place the puller jaws from the outside onto the part to be removed
- Pivot the claws under the component
- Manually pull the spindle to secure it
- Use a ratchet or a ring spanner to turn the hexagon on the spindle head until the component is loosened

MASTER DATA

GTIN [EAN]	4021176480584
Country of origin	DE
Case material	Tool steel
Series	483
Net weight [kg]	1,72 kg
Package contents	1 piece
Packaging Act	PAP 21
Global sales capability given	Yes (REACH, RoHS, POP, PROP65, TSCA)

SPARE PARTS

- 483-4-200-S_3 jaws (set)
- 483-4-206_spindle
- 483-4-T_Crossbar
- 616180_Double-sided spindle tip

3-jaw puller with force-amplifying, self-centering, tensioning jaws, up to 200 mm spread, 200 mm reach

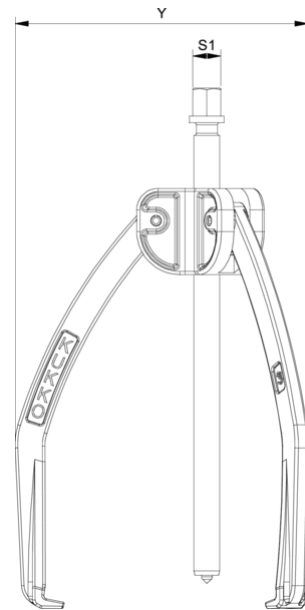
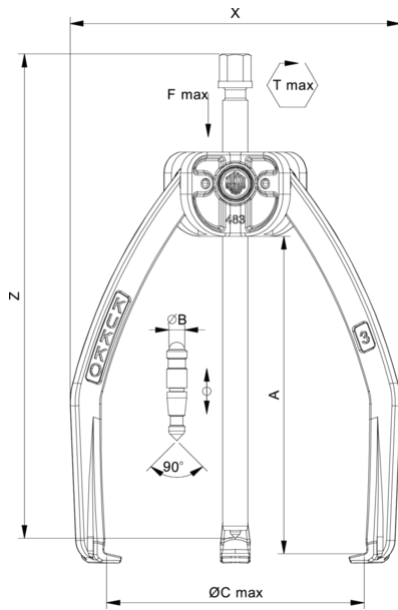

Abbreviation	Attribut	Wert
X	Total width [mm]	224 mm
Y	Total depth [mm]	33 mm
Z	Total height [mm]	295 mm
A	Clamping depth outside pull-off [mm]	200 mm
S1	Width across flats [mm]	17 mm
Cmin	Span outside pull-off (min.) [mm]	0 mm
Cmax	Span outside pull-off (max.) [mm]	200 mm
K	Hook root thickness at the tip (claw thickness K) [mm]	3,5 mm
J	Hook base width (claw width J) [mm]	16 mm
O	Hook base depth usable (claw depth usable O) [mm]	12 mm
H	Total hook root depth (total claw depth H) [mm]	24 mm
L	Total claw thickness (L+1mm) (claw distance to base surface) [mm]	6 mm
Tmax	Max. torque [Nm]	40 Nm
Fmax	Max. tractive force [t]	3 t
Fmax	Max. tensile force [kN]	30 kN

Abbreviation	Attribut	Wert
X	Total width [mm]	224 mm
Y	Total depth [mm]	33 mm
Z	Total height [mm]	295 mm
A	Clamping depth outside pull-off [mm]	200 mm
S1	Width across flats [mm]	17 mm
Cmin	Span outside pull-off (min.) [mm]	0 mm
Cmax	Span outside pull-off (max.) [mm]	200 mm
K	Hook root thickness at the tip (claw thickness K) [mm]	3,5 mm
J	Hook base width (claw width J) [mm]	16 mm
O	Hook base depth usable (claw depth usable O) [mm]	12 mm
H	Total hook root depth (total claw depth H) [mm]	24 mm
L	Total claw thickness (L+1mm) (claw distance to base surface) [mm]	6 mm
Tmax	Max. torque [Nm]	40 Nm
Fmax	Max. tractive force [t]	3 t
Fmax	Max. tensile force [kN]	30 kN

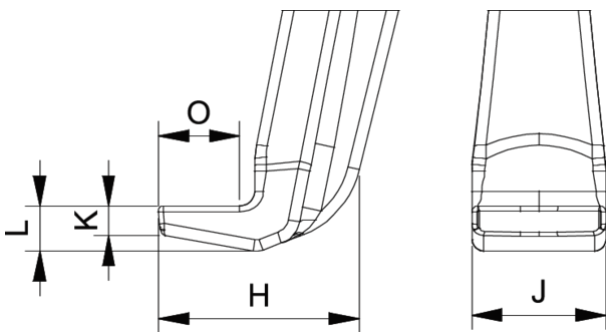

Abbreviation	Attribut	Wert
X	Total width [mm]	224 mm
Y	Total depth [mm]	33 mm
Z	Total height [mm]	295 mm
A	Clamping depth outside pull-off [mm]	200 mm

S1	Width across flats [mm]	17 mm
Cmin	Span outside pull-off (min.) [mm]	0 mm
Cmax	Span outside pull-off (max.) [mm]	200 mm
K	Hook root thickness at the tip (claw thickness K) [mm]	3,5 mm
J	Hook base width (claw width J) [mm]	16 mm
O	Hook base depth usable (claw depth usable O) [mm]	12 mm
H	Total hook root depth (total claw depth H) [mm]	24 mm
L	Total claw thickness (L+1mm) (claw distance to base surface) [mm]	6 mm
Tmax	Max. torque [Nm]	40 Nm
Fmax	Max. tractive force [t]	3 t
Fmax	Max. tensile force [kN]	30 kN