

46-1-B 2-jaw universal puller with swiveling jaws, combo crossbar, hydraulic spindle, up to 300 mm spread, 300 mm depth



DESCRIPTION

The heavy, 2-jaw universal puller with swiveling puller jaws, combination crossbar, and hydraulic spindle is used for pulling large, particularly stuck bearings, gears, and discs in all common sizes for trades, workshops, and industry. The hydraulic spindle achieves an average pulling force of up to 15 t. This allows for the loosening of any component that sits on a shaft and is accessible from outside. For pulling processes with pulling forces of up to 10 t and/or in confined spaces, the mechanical spindle can be used. The swiveling puller jaws also provide maximum freedom of movement to individually adjust to the respective spread and depth, even under restricted environmental conditions. Thanks to the combination crossbar, the puller can be used both as a 2-jaw and a 3-jaw puller.

APPLICATION AREA

For extracting large, particularly tight-fitting bearings, gears and pulleys

BENEFIT

- Swiveling jaws allow for operation in the tightest spaces while simultaneously providing individual adjustment to the spread and depth.
- The crossbar can be used as both a 2-jaw and a 3-jaw.
- Hydraulic spindle ensures easy and controlled removal of particularly tight-fitting parts with minimal effort.
- In limited space conditions that require direct access to the component, the mechanical spindle can be used.
- The mechanical spindle has a rotatable spindle tip for secure placement on smooth surfaces and centering.
- Anti-slip safety (spindle neck) at the spindle head for safe working with a wrench.
- Spindle outlet for thread protection

OPERATION

- Swivel the puller jaws from the outside onto the part to be removed
- Slide the claws under the component
- Use the T-handle to operate the hydraulic spindle
- Adjust the hydraulic spindle until the component is loose

MASTER DATA

| | |
|-------------------------------|--------------------------------------|
| GTIN [EAN] | 4021176017018 |
| Country of origin | DE |
| Case material | Tool steel |
| Series | 46-B |
| Net weight [kg] | 19,22 kg |
| Package contents | 1 piece |
| Packaging Act | PP 05 |
| Global sales capability given | Yes (REACH, RoHS, POP, PROP65, TSCA) |

SPARE PARTS

- 46-300_Puller jaws for series 46/47
- 46-47-T_Crossbar for puller 46/47
- 633370_Double-sided spindle tip
- 633400_Mechanical pressure spindle
- 8-1-F_Hydraulic Spindle

2-jaw universal puller with swiveling jaws, combo crossbar, hydraulic spindle, up to 300 mm spread, 300 mm depth

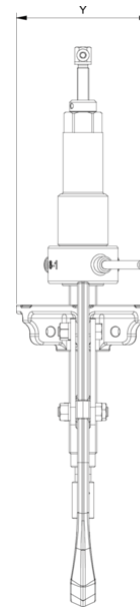
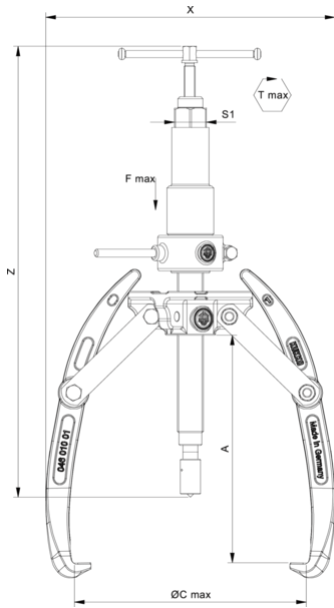

| Abbreviation | Attribut | Wert |
|--------------|---|--------|
| X | Total width [mm] | 350 mm |
| Y | Total depth [mm] | 160 mm |
| Z | Total height [mm] | 600 mm |
| A | Clamping depth outside pull-off [mm] | 300 mm |
| Cmin | Span outside pull-off (min.) [mm] | 0 mm |
| Cmax | Span outside pull-off (max.) [mm] | 300 mm |
| K | Hook root thickness at the tip (claw thickness K) [mm] | 6 mm |
| J | Hook base width (claw width J) [mm] | 30 mm |
| O | Hook base depth usable (claw depth usable O) [mm] | 25 mm |
| H | Total hook root depth (total claw depth H) [mm] | 50 mm |
| L | Total claw thickness (L+1mm) (claw distance to base surface) [mm] | 22 mm |
| Tmax | Max. torque [Nm] | 450 Nm |
| Fmax | Max. tractive force [t] | 15 t |
| Fmax | Max. tensile force [kN] | 150 kN |

| Abbreviation | Attribut | Wert |
|--------------|---|--------|
| X | Total width [mm] | 350 mm |
| Y | Total depth [mm] | 160 mm |
| Z | Total height [mm] | 600 mm |
| A | Clamping depth outside pull-off [mm] | 300 mm |
| Cmin | Span outside pull-off (min.) [mm] | 0 mm |
| Cmax | Span outside pull-off (max.) [mm] | 300 mm |
| K | Hook root thickness at the tip (claw thickness K) [mm] | 6 mm |
| J | Hook base width (claw width J) [mm] | 30 mm |
| O | Hook base depth usable (claw depth usable O) [mm] | 25 mm |
| H | Total hook root depth (total claw depth H) [mm] | 50 mm |
| L | Total claw thickness (L+1mm) (claw distance to base surface) [mm] | 22 mm |
| Tmax | Max. torque [Nm] | 450 Nm |
| Fmax | Max. tractive force [t] | 15 t |
| Fmax | Max. tensile force [kN] | 150 kN |

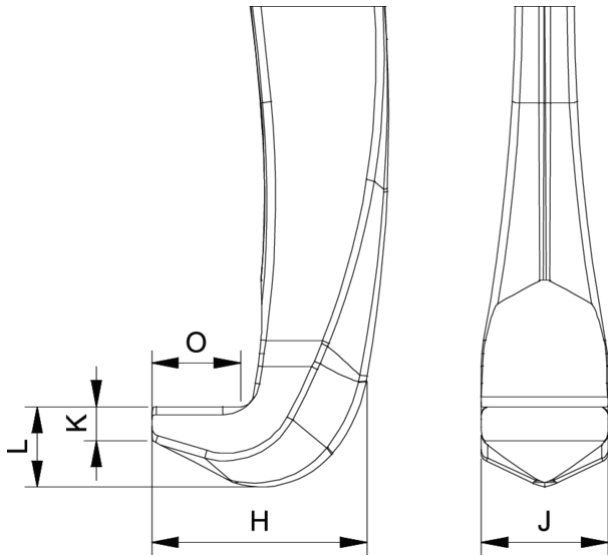

| Abbreviation | Attribut | Wert |
|--------------|---|--------|
| X | Total width [mm] | 350 mm |
| Y | Total depth [mm] | 160 mm |
| Z | Total height [mm] | 600 mm |
| A | Clamping depth outside pull-off [mm] | 300 mm |
| Cmin | Span outside pull-off (min.) [mm] | 0 mm |
| Cmax | Span outside pull-off (max.) [mm] | 300 mm |
| K | Hook root thickness at the tip (claw thickness K) [mm] | 6 mm |
| J | Hook base width (claw width J) [mm] | 30 mm |
| O | Hook base depth usable (claw depth usable O) [mm] | 25 mm |
| H | Total hook root depth (total claw depth H) [mm] | 50 mm |
| L | Total claw thickness (L+1mm) (claw distance to base surface) [mm] | 22 mm |
| Tmax | Max. torque [Nm] | 450 Nm |
| Fmax | Max. tractive force [t] | 15 t |
| Fmax | Max. tensile force [kN] | 150 kN |

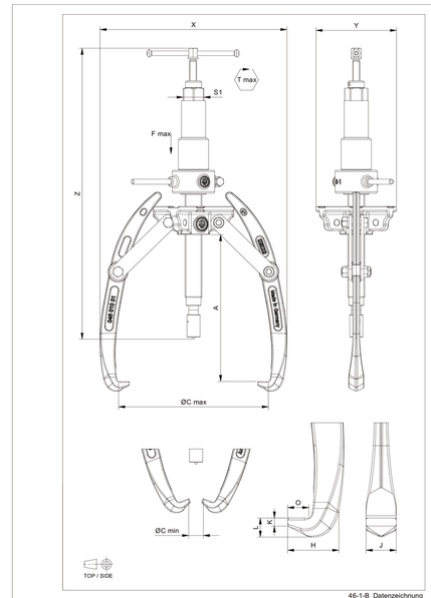

| Abbreviation | Attribut | Wert |
|--------------|---|--------|
| X | Total width [mm] | 350 mm |
| Y | Total depth [mm] | 160 mm |
| Z | Total height [mm] | 600 mm |
| A | Clamping depth outside pull-off [mm] | 300 mm |
| Cmin | Span outside pull-off (min.) [mm] | 0 mm |
| Cmax | Span outside pull-off (max.) [mm] | 300 mm |
| K | Hook root thickness at the tip (claw thickness K) [mm] | 6 mm |
| J | Hook base width (claw width J) [mm] | 30 mm |
| O | Hook base depth usable (claw depth usable O) [mm] | 25 mm |
| H | Total hook root depth (total claw depth H) [mm] | 50 mm |
| L | Total claw thickness (L+1mm) (claw distance to base surface) [mm] | 22 mm |
| Tmax | Max. torque [Nm] | 450 Nm |
| Fmax | Max. tractive force [t] | 15 t |
| Fmax | Max. tensile force [kN] | 150 kN |