

# 42-5 3-jaw universal puller with swiveling jaws, up to 180 mm spread, 200 mm reach



APPLICATION IMAGE



DETAIL IMAGE



## DESCRIPTION

The 3-jaw universal puller with swiveling jaws is used for pulling bearings, gears, and discs in all common sizes for crafts, workshops, and industry. It allows for the loosening of any component that is mounted on a shaft and accessible from the outside. The swiveling jaws also provide maximum freedom of movement for individual adaptation to the respective spread and depth, even in restricted environmental conditions. The 3-jaw design guarantees an even weight distribution and thus a particularly secure hold on the part being pulled. Within series 42, there are various designs of the puller. Up to model 41-2, the puller is equipped with a T-handle and a flat pressure piece for work in tight spaces. Starting from model 42-3, the puller features a hexagon drive and a dual spindle tip. This allows for achieving the highest pulling forces (3 to 7 tons).

## APPLICATION AREA

For pulling off bearings, gears and pulleys

## BENEFIT

- Swiveling puller jaws allow for work in tight spaces while simultaneously providing individual adjustment for spread and reach.
- 3-jaw provides an even distribution of force and allows for greater pulling forces.
- Anti-slip safety (spindle neck) at spindle head for safe working with wrench.
- Spindle outlet to protect the thread
- Secure installation of the spindle through a rotatable spindle tip on both smooth surfaces and during centering (Switch Technology) (applies from size 42-3)
- Integrated, freely movable T-handle guarantees manual spindle drive in confined spaces (applies up to size 41-2)

## OPERATION

- Swivel the puller jaws from the outside onto the part to be pulled off
- Slide the claws under the component
- Manually pull the spindle for fixation
- Manually operate the T-handle or set the hexagon head on the spindle with a ratchet or an open-end wrench until the component is released

## MASTER DATA

GTIN [EAN]	4021176836596
Country of origin	DE
Case material	Tool steel
Series	42
Net weight [kg]	4,295 kg
Package contents	1 piece
Packaging Act	PAP 21
Global sales capability given	Yes (REACH, RoHS, POP, PROP65, TSCA)

## SPARE PARTS

- 202-2-T\_Crossbar
- 42-5-200-S\_3 puller set
- 621300\_Mechanical pressure spindle

# 3-jaw universal puller with swiveling jaws, up to 180 mm spread, 200 mm reach

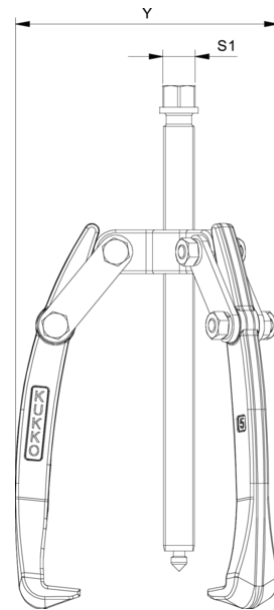
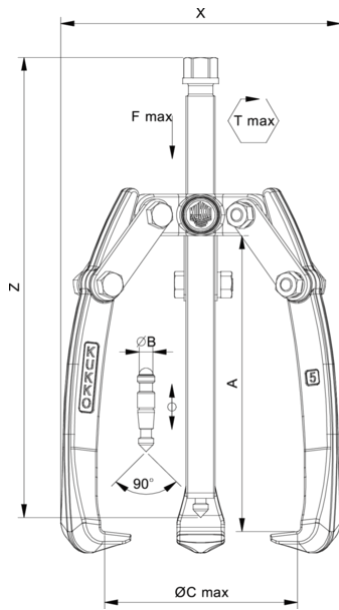

Abbreviation	Attribut	Wert
X	Total width [mm]	204 mm
Y	Total depth [mm]	204 mm
Z	Total height [mm]	325 mm
A	Clamping depth outside pull-off [mm]	200 mm
S1	Width across flats [mm]	22 mm
Cmin	Span outside pull-off (min.) [mm]	0 mm
Cmax	Span outside pull-off (max.) [mm]	180 mm
K	Hook root thickness at the tip (claw thickness K) [mm]	5 mm
J	Hook base width (claw width J) [mm]	34 mm
O	Hook base depth usable (claw depth usable O) [mm]	23 mm
H	Total hook root depth (total claw depth H) [mm]	35 mm
L	Total claw thickness (L+1mm) (claw distance to base surface) [mm]	15 mm
Tmax	Max. torque [Nm]	150 Nm
Fmax	Max. tractive force [t]	7 t
Fmax	Max. tensile force [kN]	70 kN

Abbreviation	Attribut	Wert
X	Total width [mm]	204 mm
Y	Total depth [mm]	204 mm
Z	Total height [mm]	325 mm
A	Clamping depth outside pull-off [mm]	200 mm
S1	Width across flats [mm]	22 mm
Cmin	Span outside pull-off (min.) [mm]	0 mm
Cmax	Span outside pull-off (max.) [mm]	180 mm
K	Hook root thickness at the tip (claw thickness K) [mm]	5 mm
J	Hook base width (claw width J) [mm]	34 mm
O	Hook base depth usable (claw depth usable O) [mm]	23 mm
H	Total hook root depth (total claw depth H) [mm]	35 mm
L	Total claw thickness (L+1mm) (claw distance to base surface) [mm]	15 mm
Tmax	Max. torque [Nm]	150 Nm
Fmax	Max. tractive force [t]	7 t
Fmax	Max. tensile force [kN]	70 kN

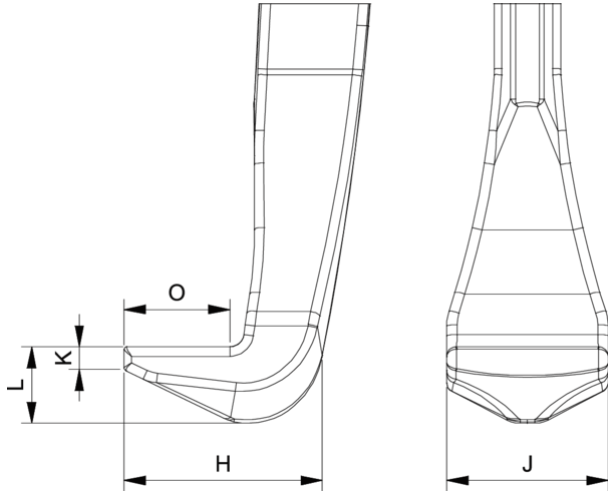

Abbreviation	Attribut	Wert
X	Total width [mm]	204 mm
Y	Total depth [mm]	204 mm
Z	Total height [mm]	325 mm
A	Clamping depth outside pull-off [mm]	200 mm
S1	Width across flats [mm]	22 mm
Cmin	Span outside pull-off (min.) [mm]	0 mm
Cmax	Span outside pull-off (max.) [mm]	180 mm
K	Hook root thickness at the tip (claw thickness K) [mm]	5 mm
J	Hook base width (claw width J) [mm]	34 mm
O	Hook base depth usable (claw depth usable O) [mm]	23 mm
H	Total hook root depth (total claw depth H) [mm]	35 mm
L	Total claw thickness (L+1mm) (claw distance to base surface) [mm]	15 mm
Tmax	Max. torque [Nm]	150 Nm
Fmax	Max. tractive force [t]	7 t
Fmax	Max. tensile force [kN]	70 kN

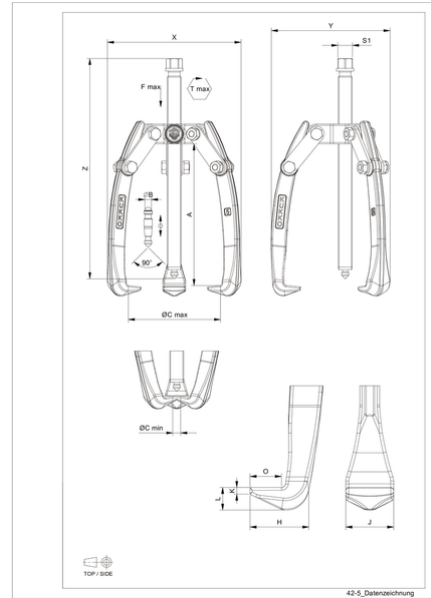

Abbreviation	Attribut	Wert
X	Total width [mm]	204 mm
Y	Total depth [mm]	204 mm
Z	Total height [mm]	325 mm
A	Clamping depth outside pull-off [mm]	200 mm
S1	Width across flats [mm]	22 mm
Cmin	Span outside pull-off (min.) [mm]	0 mm
Cmax	Span outside pull-off (max.) [mm]	180 mm
K	Hook root thickness at the tip (claw thickness K) [mm]	5 mm
J	Hook base width (claw width J) [mm]	34 mm
O	Hook base depth usable (claw depth usable O) [mm]	23 mm
H	Total hook root depth (total claw depth H) [mm]	35 mm
L	Total claw thickness (L+1mm) (claw distance to base surface) [mm]	15 mm
Tmax	Max. torque [Nm]	150 Nm
Fmax	Max. tractive force [t]	7 t
Fmax	Max. tensile force [kN]	70 kN