

41-0 2-jaw universal puller with swiveling jaws, up to 60 mm spread, 40 mm reach



APPLICATION IMAGE



DESCRIPTION

The 2-jaw universal puller with swiveling jaws is used for pulling bearings, gears, and discs in all common sizes for crafts, workshops, and industry. It allows for the loosening of any component that sits on a shaft and is externally accessible. The swiveling jaws also provide maximum freedom of movement for individual adjustment to the respective spread and depth, even in restricted environmental conditions. Within series 41, there are various versions of the puller. The compact model 41-0 features a hexagon drive and a flat pressure piece on the spindle. The models 41-1 and 41-2 have a freely movable T-handle instead of the hexagon, allowing for work in tight spaces. Starting from size 41-3, the pullers are equipped with a hexagon drive and a dual spindle tip. This allows for the largest pulling forces to be achieved (3 to 7 tons).

APPLICATION AREA

For pulling off bearings, gears and pulleys

BENEFIT

- Swiveling puller jaws allow for work in tight spaces while simultaneously providing individual adjustment for spread and reach.
- Anti-slip safety (spindle neck) at the spindle head for safe work with wrench
- Spindle outlet for thread protection
- Safe setup of the spindle via a rotatable spindle tip on both smooth surfaces and during centering (Switch Technology) (applies from size 41-3).
- Integrated, freely movable T-handle guarantees manual spindle drive in the tightest spaces (applies only to sizes 41-1 and 41-2)

OPERATION

- Swing the puller jaws from the outside onto the part to be pulled off
- Slide the claws under the component
- Manually pull the spindle to lock it in place
- Manually operate the T-handle or turn the hexagon at the spindle head with a ratchet or a box wrench until the component is released

MASTER DATA

GTIN [EAN]	4021176362859
Country of origin	DE
Case material	Tool steel
Series	41
Net weight [kg]	0,25 kg
Package contents	1 piece
Packaging Act	PAP 21
Global sales capability given	Yes (REACH, RoHS, POP, PROP65, TSCA)

SPARE PARTS

- 41-0-40-P_2 jaws (pair)
- 41-0-T_Crossbar
- 610070_Mechanical pressure spindle

2-jaw universal puller with swiveling jaws, up to 60 mm spread, 40 mm reach

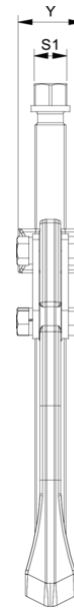
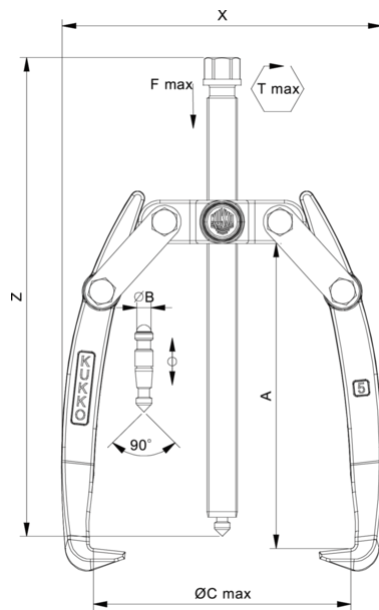

Abbreviation	Attribut	Wert
X	Total width [mm]	76 mm
Y	Total depth [mm]	17 mm
Z	Total height [mm]	97 mm
A	Clamping depth outside pull-off [mm]	40 mm
S1	Width across flats [mm]	13 mm
Cmin	Span outside pull-off (min.) [mm]	0 mm
Cmax	Span outside pull-off (max.) [mm]	60 mm
K	Hook root thickness at the tip (claw thickness K) [mm]	2 mm
J	Hook base width (claw width J) [mm]	10,5 mm
O	Hook base depth usable (claw depth usable O) [mm]	7 mm
H	Total hook root depth (total claw depth H) [mm]	15 mm
L	Total claw thickness (L+1mm) (claw distance to base surface) [mm]	4 mm
Tmax	Max. torque [Nm]	25 Nm
Fmax	Max. tractive force [t]	1 t
Fmax	Max. tensile force [kN]	10 kN

Abbreviation	Attribut	Wert
X	Total width [mm]	76 mm
Y	Total depth [mm]	17 mm
Z	Total height [mm]	97 mm
A	Clamping depth outside pull-off [mm]	40 mm
S1	Width across flats [mm]	13 mm
Cmin	Span outside pull-off (min.) [mm]	0 mm
Cmax	Span outside pull-off (max.) [mm]	60 mm
K	Hook root thickness at the tip (claw thickness K) [mm]	2 mm
J	Hook base width (claw width J) [mm]	10,5 mm
O	Hook base depth usable (claw depth usable O) [mm]	7 mm
H	Total hook root depth (total claw depth H) [mm]	15 mm
L	Total claw thickness (L+1mm) (claw distance to base surface) [mm]	4 mm
Tmax	Max. torque [Nm]	25 Nm
Fmax	Max. tractive force [t]	1 t
Fmax	Max. tensile force [kN]	10 kN

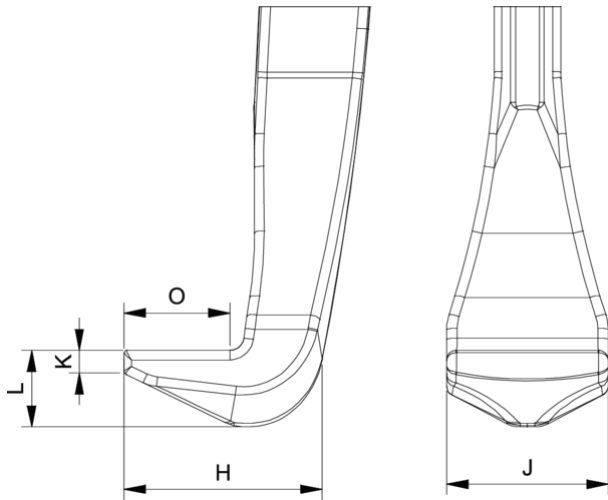

Abbreviation	Attribut	Wert
X	Total width [mm]	76 mm
Y	Total depth [mm]	17 mm
Z	Total height [mm]	97 mm
A	Clamping depth outside pull-off [mm]	40 mm
S1	Width across flats [mm]	13 mm
Cmin	Span outside pull-off (min.) [mm]	0 mm
Cmax	Span outside pull-off (max.) [mm]	60 mm
K	Hook root thickness at the tip (claw thickness K) [mm]	2 mm
J	Hook base width (claw width J) [mm]	10,5 mm
O	Hook base depth usable (claw depth usable O) [mm]	7 mm
H	Total hook root depth (total claw depth H) [mm]	15 mm
L	Total claw thickness (L+1mm) (claw distance to base surface) [mm]	4 mm
Tmax	Max. torque [Nm]	25 Nm
Fmax	Max. tractive force [t]	1 t
Fmax	Max. tensile force [kN]	10 kN