

20-5-H 2-jaw universal puller with hydraulic spindle, spread 105 mm to 750 mm, reach 750 mm

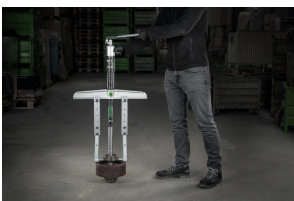

APPLICATION IMAGE



DESCRIPTION

The 2-arm universal puller with adjustable clamping depth is used to pull bearings, gears and washers in all common sizes for trade, workshop and industry. The 20-5 is the largest of its kind in the world and therefore the most powerful puller in the 20 series. It can be used to remove any component that sits on a shaft and is freely accessible from the outside. Thanks to its individually adjustable clamping width and depth, the puller adapts to any pulling situation and guarantees particularly safe, non-destructive removal both on external removal and internal extraction.

APPLICATION AREA

For pulling off bearings, gears and pulleys

BENEFIT

- The screw connection allows for easy loosening and particularly tight fastening of the jaws with an allen key
- Application also for eccentric components through freely movable jaws gliding on the crossbar
- Variable adjustment for any span between 105 mm – 750 mm as well as reach depth between 750 mm – 750 mm
- Fat hydraulic spindle ensures easy and controlled removal of tightly seated parts with minimal effort.
- Optional convertible from an external puller to an internal extractor by reversing the extractor jaws.
- Anti-slip safety (spindle neck) at the spindle head for safe working with a wrench
- Spindle run-out to protect the thread

OPERATION

- Position the puller jaws on the part to be removed from the outside
- Slide the jaws under the component
- Use a wrench to secure the jaws
- Manually pull the spindle to lock it in place
- Activate the lever arm on the hydraulic pump until the part is released

MASTER DATA

GTIN [EAN]	4021176228063
Country of origin	DE
Case material	Tool steel
Series	20-H
Net weight [kg]	54 kg
Package contents	1 piece
Packaging Act	PAP 21
Global sales capability given	Yes (REACH, RoHS, POP, PROP65, TSCA)

SPARE PARTS

- 20-4-T_crossbar for 20-4
- 20-5-T_traverse with socket for 20-5
- 4-SP-P_jaws with adjustable length (pair)
- 5-SP-P_jaws with adjustable length (pair)
- 633370_Double-sided spindle tip
- 8-2-Jaw Long Hydraulic Spindle
- 8-HP-637_Hydraulic spindle with hand lever operation

2-jaw universal puller with hydraulic spindle, spread 105 mm to 750 mm, reach 750 mm

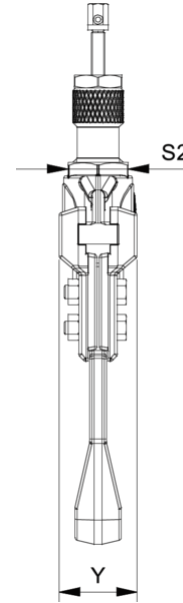
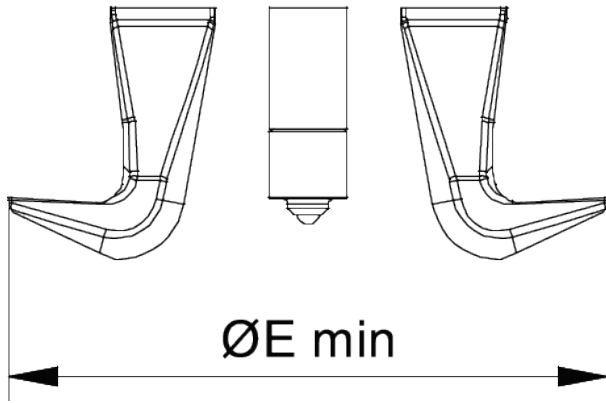

Abbreviation	Attribut	Wert
A	Clamping depth outside pull-off [mm]	750 mm
Cmin	Span outside pull-off (min.) [mm]	105 mm
Cmax	Span outside pull-off (max.) [mm]	750 mm
A1	Clamping depth of external pull-off A1 [mm]	500 mm
A2	Clamping depth outside pull-off A2 [mm]	550 mm
A3	Clamping depth external pull-off A3 [mm]	580 mm
A5	Clamping depth external peel-off A5 [mm]	750 mm
A4	Clamping depth outside pull-off A4 [mm]	600 mm
K	Hook root thickness at the tip (claw thickness K) [mm]	10 mm
J	Hook base width (claw width J) [mm]	60 mm
O	Hook base depth usable (claw depth usable O) [mm]	60 mm
H	Total hook root depth (total claw depth H) [mm]	100 mm
L	Total claw thickness (L+1mm) (claw distance to base surface) [mm]	40 mm
Emin	Span inside pull-out (min.) [mm]	340 mm
Emax	Span inside pull-out (max.) [mm]	1.000 mm
Fmax	Max. tractive force [t]	20 t
Fmax	Max. tensile force [kN]	120 kN

Abbreviation	Attribut	Wert
A	Clamping depth outside pull-off [mm]	750 mm
Cmin	Span outside pull-off (min.) [mm]	105 mm
Cmax	Span outside pull-off (max.) [mm]	750 mm
A1	Clamping depth of external pull-off A1 [mm]	500 mm
A2	Clamping depth outside pull-off A2 [mm]	550 mm
A3	Clamping depth external pull-off A3 [mm]	580 mm
A5	Clamping depth external peel-off A5 [mm]	750 mm
A4	Clamping depth outside pull-off A4 [mm]	600 mm
K	Hook root thickness at the tip (claw thickness K) [mm]	10 mm
J	Hook base width (claw width J) [mm]	60 mm
O	Hook base depth usable (claw depth usable O) [mm]	60 mm
H	Total hook root depth (total claw depth H) [mm]	100 mm
L	Total claw thickness (L+1mm) (claw distance to base surface) [mm]	40 mm
Emin	Span inside pull-out (min.) [mm]	340 mm
Emax	Span inside pull-out (max.) [mm]	1.000 mm
Fmax	Max. tractive force [t]	20 t
Fmax	Max. tensile force [kN]	120 kN

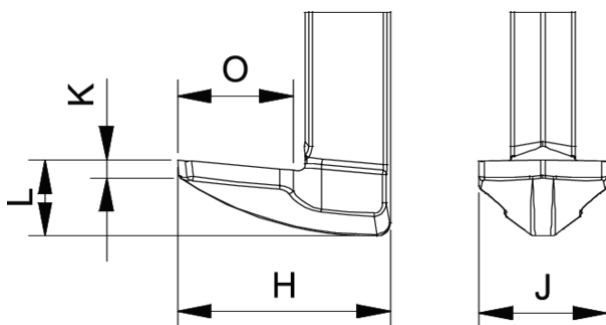

Abbreviation	Attribut	Wert
A	Clamping depth outside pull-off [mm]	750 mm

Cmin	Span outside pull-off (min.) [mm]	105 mm
Cmax	Span outside pull-off (max.) [mm]	750 mm
A1	Clamping depth of external pull-off A1 [mm]	500 mm
A2	Clamping depth outside pull-off A2 [mm]	550 mm
A3	Clamping depth external pull-off A3 [mm]	580 mm
A5	Clamping depth external peel-off A5 [mm]	750 mm
A4	Clamping depth outside pull-off A4 [mm]	600 mm
K	Hook root thickness at the tip (claw thickness K) [mm]	10 mm
J	Hook base width (claw width J) [mm]	60 mm
O	Hook base depth usable (claw depth usable O) [mm]	60 mm
H	Total hook root depth (total claw depth H) [mm]	100 mm
L	Total claw thickness (L+1mm) (claw distance to base surface) [mm]	40 mm
Emin	Span inside pull-out (min.) [mm]	340 mm
Emax	Span inside pull-out (max.) [mm]	1.000 mm
Fmax	Max. tractive force [t]	20 t
Fmax	Max. tensile force [kN]	120 kN

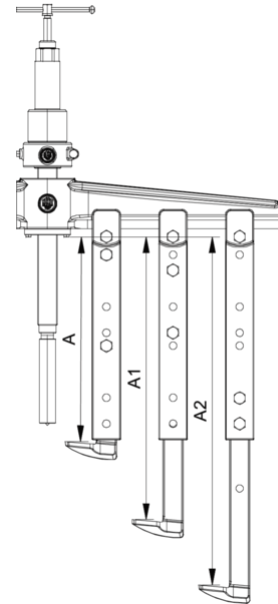

Abbreviation	Attribut	Wert
A	Clamping depth outside pull-off [mm]	750 mm
Cmin	Span outside pull-off (min.) [mm]	105 mm
Cmax	Span outside pull-off (max.) [mm]	750 mm
A1	Clamping depth of external pull-off A1 [mm]	500 mm
A2	Clamping depth outside pull-off A2 [mm]	550 mm
A3	Clamping depth external pull-off A3 [mm]	580 mm
A5	Clamping depth external peel-off A5 [mm]	750 mm
A4	Clamping depth outside pull-off A4 [mm]	600 mm
K	Hook root thickness at the tip (claw thickness K) [mm]	10 mm
J	Hook base width (claw width J) [mm]	60 mm
O	Hook base depth usable (claw depth usable O) [mm]	60 mm
H	Total hook root depth (total claw depth H) [mm]	100 mm
L	Total claw thickness (L+1mm) (claw distance to base surface) [mm]	40 mm
Emin	Span inside pull-out (min.) [mm]	340 mm
Emax	Span inside pull-out (max.) [mm]	1.000 mm
Fmax	Max. tractive force [t]	20 t
Fmax	Max. tensile force [kN]	120 kN

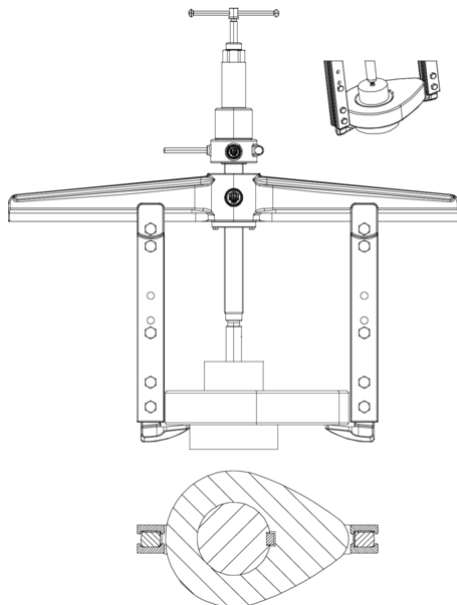

Abbreviation	Attribut	Wert
A	Clamping depth outside pull-off [mm]	750 mm
Cmin	Span outside pull-off (min.) [mm]	105 mm
Cmax	Span outside pull-off (max.) [mm]	750 mm
A1	Clamping depth of external pull-off A1 [mm]	500 mm
A2	Clamping depth outside pull-off A2 [mm]	550 mm

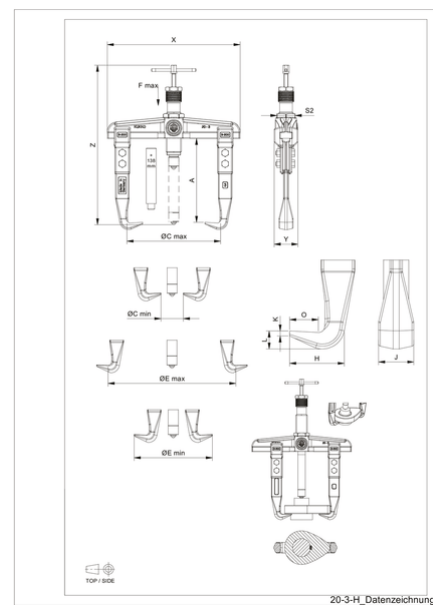

Abbreviation	Attribut	Wert
A	Clamping depth outside pull-off [mm]	750 mm
Cmin	Span outside pull-off (min.) [mm]	105 mm
Cmax	Span outside pull-off (max.) [mm]	750 mm
A1	Clamping depth of external pull-off A1 [mm]	500 mm
A2	Clamping depth outside pull-off A2 [mm]	550 mm

A3	Clamping depth external pull-off A3 [mm]	580 mm
A5	Clamping depth external peel-off A5 [mm]	750 mm
A4	Clamping depth outside pull-off A4 [mm]	600 mm
K	Hook root thickness at the tip (claw thickness K) [mm]	10 mm
J	Hook base width (claw width J) [mm]	60 mm
O	Hook base depth usable (claw depth usable O) [mm]	60 mm
H	Total hook root depth (total claw depth H) [mm]	100 mm
L	Total claw thickness (L+1mm) (claw distance to base surface) [mm]	40 mm
Emin	Span inside pull-out (min.) [mm]	340 mm
Emax	Span inside pull-out (max.) [mm]	1.000 mm
Fmax	Max. tractive force [t]	20 t
Fmax	Max. tensile force [kN]	120 kN

A3	Clamping depth external pull-off A3 [mm]	580 mm
A5	Clamping depth external peel-off A5 [mm]	750 mm
A4	Clamping depth outside pull-off A4 [mm]	600 mm
K	Hook root thickness at the tip (claw thickness K) [mm]	10 mm
J	Hook base width (claw width J) [mm]	60 mm
O	Hook base depth usable (claw depth usable O) [mm]	60 mm
H	Total hook root depth (total claw depth H) [mm]	100 mm
L	Total claw thickness (L+1mm) (claw distance to base surface) [mm]	40 mm
Emin	Span inside pull-out (min.) [mm]	340 mm
Emax	Span inside pull-out (max.) [mm]	1.000 mm
Fmax	Max. tractive force [t]	20 t
Fmax	Max. tensile force [kN]	120 kN