

20-2+ 2-jaw universal puller with quick-adjustment jaws, up to 160 mm spread, 162 mm reach



APPLICATION IMAGE



DETAIL IMAGE



DESCRIPTION

The 2-jaw universal puller is used for extracting bearings, gears, and discs in all common sizes for crafts, workshops, and industry. It can loosen any component that sits on a shaft and is freely accessible from the outside. Equipped with robust and adjustable standard jaws, the puller all-rounder ensures particularly safe, non-destructive disassembly when performing external extraction as well as internal extraction.

APPLICATION AREA

For pulling off bearings, gears and pulleys

BENEFIT

- The screw connection allows for easy loosening and particularly tight fastening of the jaws with an allen key
- Application also for eccentric components through freely movable, sliding puller jaws on the crossbar.
- Hexagonal profile on the crossbar for secure counter-holding
- Variable adjustment for any spread between 10 mm – 160 mm
- Safe shear suspension of the claw in the sliding piece (Armlock Technology)
- Secure mounting of the spindle through the rotatable spindle tip on both smooth surfaces and in centering (Switch Technology)
- Optional convertible from an external puller to an internal extractor by reversing the jaws.
- Anti-slip safety (spindle neck) at spindle head for safe working with wrench
- Spindle run-out to protect the thread

OPERATION

- Position the puller jaws from the outside onto the part to be removed
- Push the claws under the component
- Use a wrench to secure the jaws
- Manually apply pressure to the spindle for fixation
- Set the hexagon on the spindle head in motion with a ratchet or open-end wrench until the component is released

MASTER DATA

GTIN [EAN]	4021176644931
Country of origin	DE
Case material	Tool steel
Series	20+
Net weight [kg]	3,45 kg
Package contents	1 piece
Packaging Act	PAP 21
Global sales capability given	Yes (REACH, RoHS, POP, PROP65, TSCA)

SPARE PARTS

- 2-152-P_Quick adjustable standard jaws (pair)
- 20-2-T_Crossbar for 20-2
- 620260_Two-sided spindle tip
- 621220_Mechanical pressure spindle

2-jaw universal puller with quick-adjustment jaws, up to 160 mm spread, 162 mm reach

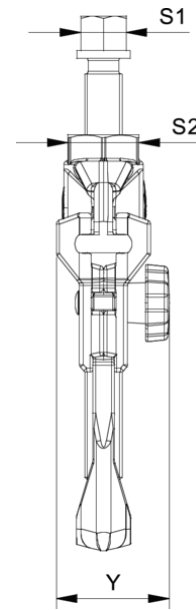
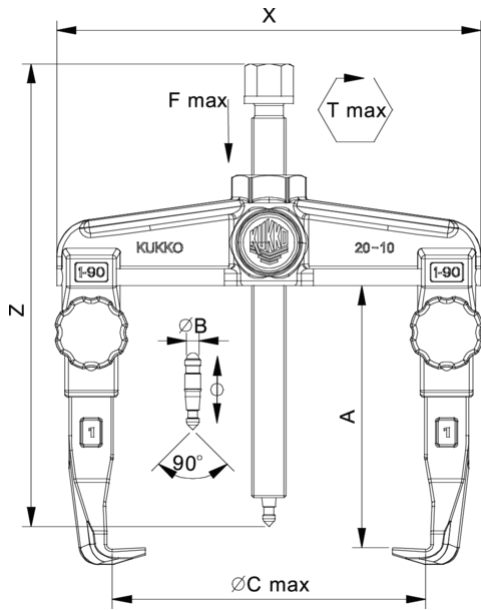

Abbreviation	Attribut	Wert
X	Total width [mm]	216 mm
Y	Total depth [mm]	50 mm
Z	Total height [mm]	254 mm
A	Clamping depth outside pull-off [mm]	162 mm
S1	Width across flats [mm]	22 mm
S2	Width across flats [mm]	36 mm
Cmin	Span outside pull-off (min.) [mm]	10 mm
Cmax	Span outside pull-off (max.) [mm]	160 mm
K	Hook root thickness at the tip (claw thickness K) [mm]	5 mm
J	Hook base width (claw width J) [mm]	24 mm
O	Hook base depth usable (claw depth usable O) [mm]	15 mm
H	Total hook root depth (total claw depth H) [mm]	40 mm
Emin	Span inside pull-out (min.) [mm]	100 mm
Emax	Span inside pull-out (max.) [mm]	220 mm
Tmax	Max. torque [Nm]	150 Nm
Fmax	Max. tractive force [t]	6 t
Fmax	Max. tensile force [kN]	60 kN

Abbreviation	Attribut	Wert
X	Total width [mm]	216 mm
Y	Total depth [mm]	50 mm
Z	Total height [mm]	254 mm
A	Clamping depth outside pull-off [mm]	162 mm
S1	Width across flats [mm]	22 mm
S2	Width across flats [mm]	36 mm
Cmin	Span outside pull-off (min.) [mm]	10 mm
Cmax	Span outside pull-off (max.) [mm]	160 mm
K	Hook root thickness at the tip (claw thickness K) [mm]	5 mm
J	Hook base width (claw width J) [mm]	24 mm
O	Hook base depth usable (claw depth usable O) [mm]	15 mm
H	Total hook root depth (total claw depth H) [mm]	40 mm
Emin	Span inside pull-out (min.) [mm]	100 mm
Emax	Span inside pull-out (max.) [mm]	220 mm
Tmax	Max. torque [Nm]	150 Nm
Fmax	Max. tractive force [t]	6 t
Fmax	Max. tensile force [kN]	60 kN

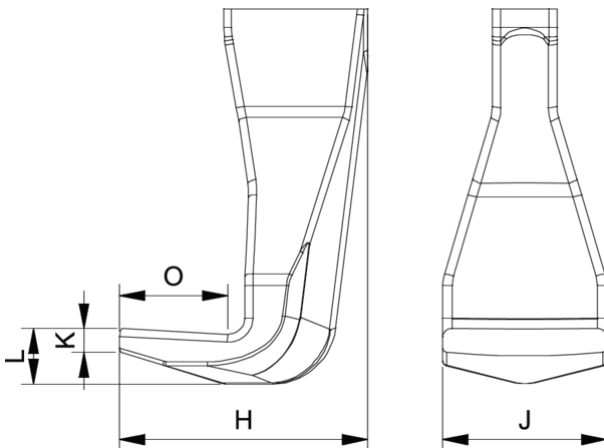

Abbreviation	Attribut	Wert
X	Total width [mm]	216 mm
Y	Total depth [mm]	50 mm
Z	Total height [mm]	254 mm
A	Clamping depth outside pull-off [mm]	162 mm
S1	Width across flats [mm]	22 mm
S2	Width across flats [mm]	36 mm
Cmin	Span outside pull-off (min.) [mm]	10 mm
Cmax	Span outside pull-off (max.) [mm]	160 mm
K	Hook root thickness at the tip (claw thickness K) [mm]	5 mm
J	Hook base width (claw width J) [mm]	24 mm
O	Hook base depth usable (claw depth usable O) [mm]	15 mm
H	Total hook root depth (total claw depth H) [mm]	40 mm
Emin	Span inside pull-out (min.) [mm]	100 mm
Emax	Span inside pull-out (max.) [mm]	220 mm
Tmax	Max. torque [Nm]	150 Nm
Fmax	Max. tractive force [t]	6 t
Fmax	Max. tensile force [kN]	60 kN

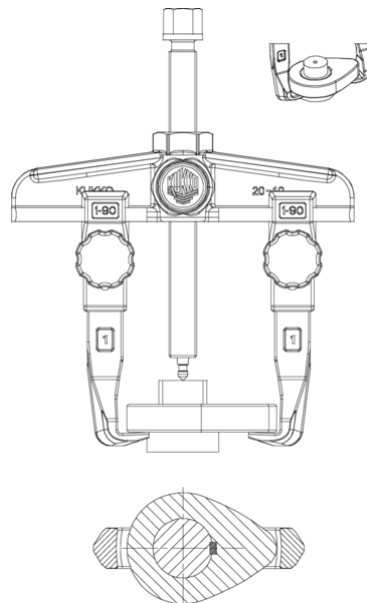

Abbreviation	Attribut	Wert
X	Total width [mm]	216 mm
Y	Total depth [mm]	50 mm
Z	Total height [mm]	254 mm
A	Clamping depth outside pull-off [mm]	162 mm
S1	Width across flats [mm]	22 mm
S2	Width across flats [mm]	36 mm
Cmin	Span outside pull-off (min.) [mm]	10 mm
Cmax	Span outside pull-off (max.) [mm]	160 mm
K	Hook root thickness at the tip (claw thickness K) [mm]	5 mm
J	Hook base width (claw width J) [mm]	24 mm
O	Hook base depth usable (claw depth usable O) [mm]	15 mm
H	Total hook root depth (total claw depth H) [mm]	40 mm
Emin	Span inside pull-out (min.) [mm]	100 mm
Emax	Span inside pull-out (max.) [mm]	220 mm
Tmax	Max. torque [Nm]	150 Nm
Fmax	Max. tractive force [t]	6 t
Fmax	Max. tensile force [kN]	60 kN