

30-2-3 3-jaw universal puller, up to 160 mm spread, 300 mm reach with extended jaws



DESCRIPTION

The 3-jaw universal puller is used for pulling bearings, gears, and discs in all common sizes for crafts, workshops, and industry. It allows you to loosen any component that sits on a shaft and is freely accessible from the outside. Equipped with robust and adjustable standard jaws, the puller all-rounder ensures particularly safe, non-destructive disassembly both during external extraction and internal extraction. The 3-jaw design guarantees even load distribution and thus a particularly secure hold on the part being pulled.

APPLICATION AREA

For pulling off bearings, gears and pulleys

BENEFIT

- The screw connection enables easy loosening and particularly tight fastening of the jaws with an allen key
- 3-jaw ensures an even distribution of force and allows for greater pulling forces.
- Application also for eccentric components through freely movable, sliding puller jaws on the crossbar.
- Hexagonal profile on the crossbar for secure counterholding
- Variable adjustment to any span between 5 mm – 160 mm
- Anti-slip safety clamping of the claw in the sliding piece (Armlock Technology)
- Safe setup of the spindle through a rotatable spindle tip on both smooth surfaces and when centering (Switch Technology)
- Optional convertible from an external puller to an internal extractor by reversing the jaws.
- Anti-slip safety (spindle neck) at the spindle head for safe work with wrench
- Spindle output to protect the thread

OPERATION

- Position the puller jaws externally on the part to be removed
- Slide the jaws under the component
- Use a wrench to secure the jaws
- Manually pull the spindle for fixation
- Turn the hexagon at the spindle head with a ratchet or a claw wrench until the component is loosened

MASTER DATA

GTIN [EAN]	4021176730986
Country of origin	DE
Case material	Tool steel
Series	30-Classic
Net weight [kg]	5,565 kg
Package contents	1 piece
Packaging Act	PAP 21
Global sales capability given	Yes (REACH, RoHS, POP, PROP65, TSCA)

SPARE PARTS

- 2-300-S_Standard-jaws (set)
- 30-2-T_Crossbar
- 621220_Mechanical pressure spindle

3-jaw universal puller, up to 160 mm spread, 300 mm reach with extended jaws

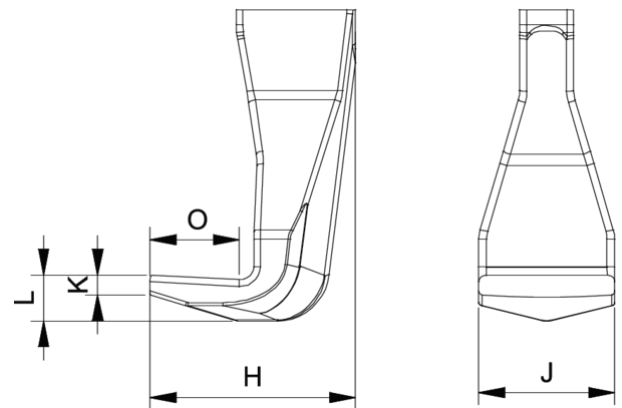
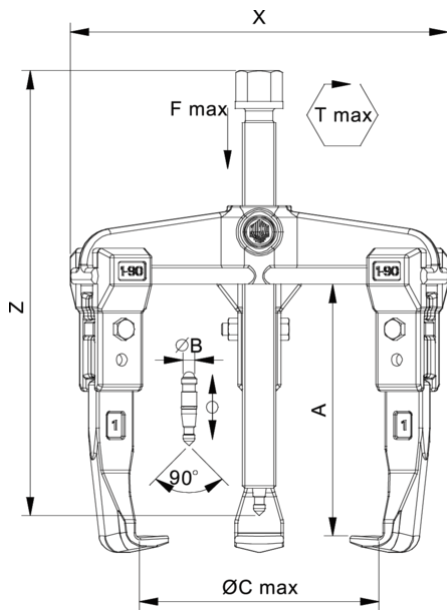

Abbreviation	Attribut	Wert
X	Total width [mm]	216 mm
Y	Total depth [mm]	216 mm
Z	Total height [mm]	254 mm
A	Clamping depth outside pull-off [mm]	300 mm
S1	Width across flats [mm]	22 mm
Cmin	Span outside pull-off (min.) [mm]	5 mm
Cmax	Span outside pull-off (max.) [mm]	160 mm
K	Hook root thickness at the tip (claw thickness K) [mm]	5 mm
J	Hook base width (claw width J) [mm]	24 mm
O	Hook base depth usable (claw depth usable O) [mm]	15 mm
H	Total hook root depth (total claw depth H) [mm]	40 mm
Emin	Span inside pull-out (min.) [mm]	100 mm
Emax	Span inside pull-out (max.) [mm]	220 mm
Tmax	Max. torque [Nm]	150 Nm
Fmax	Max. tractive force [t]	7 t
Fmax	Max. tensile force [kN]	70 kN

Abbreviation	Attribut	Wert
X	Total width [mm]	216 mm
Y	Total depth [mm]	216 mm
Z	Total height [mm]	254 mm
A	Clamping depth outside pull-off [mm]	300 mm
S1	Width across flats [mm]	22 mm
Cmin	Span outside pull-off (min.) [mm]	5 mm
Cmax	Span outside pull-off (max.) [mm]	160 mm
K	Hook root thickness at the tip (claw thickness K) [mm]	5 mm
J	Hook base width (claw width J) [mm]	24 mm
O	Hook base depth usable (claw depth usable O) [mm]	15 mm
H	Total hook root depth (total claw depth H) [mm]	40 mm
Emin	Span inside pull-out (min.) [mm]	100 mm
Emax	Span inside pull-out (max.) [mm]	220 mm
Tmax	Max. torque [Nm]	150 Nm
Fmax	Max. tractive force [t]	7 t
Fmax	Max. tensile force [kN]	70 kN

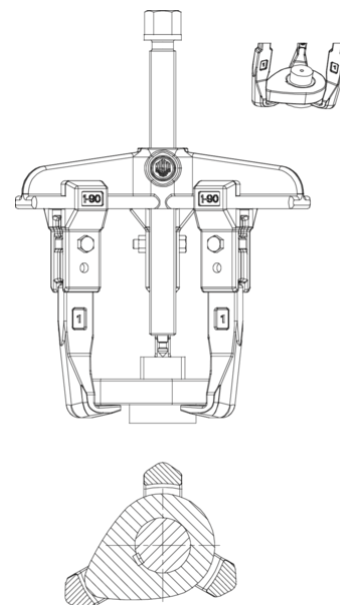

Abbreviation	Attribut	Wert
X	Total width [mm]	216 mm

Y	Total depth [mm]	216 mm
Z	Total height [mm]	254 mm
A	Clamping depth outside pull-off [mm]	300 mm
S1	Width across flats [mm]	22 mm
Cmin	Span outside pull-off (min.) [mm]	5 mm
Cmax	Span outside pull-off (max.) [mm]	160 mm
K	Hook root thickness at the tip (claw thickness K) [mm]	5 mm
J	Hook base width (claw width J) [mm]	24 mm
O	Hook base depth usable (claw depth usable O) [mm]	15 mm
H	Total hook root depth (total claw depth H) [mm]	40 mm
Emin	Span inside pull-out (min.) [mm]	100 mm
Emax	Span inside pull-out (max.) [mm]	220 mm
Tmax	Max. torque [Nm]	150 Nm
Fmax	Max. tractive force [t]	7 t
Fmax	Max. tensile force [kN]	70 kN