

20-2-3-B 2-jaw universal puller with adjustable jaws, greased hydraulic spindle, up to 160 mm spread, 300 mm reach



DESCRIPTION

The 2-jaw universal puller with extended jaws and hydraulic spindle is used for particularly safe extraction of extremely firmly and deeply seated bearings, gears, and discs in all common sizes for crafts, workshops, and industry. The hydraulic spindle achieves a pulling force of 20 tons. This allows for the loosening of any component that sits on a shaft and is freely accessible from the outside. For extraction operations with a pulling force of up to 10 tons and/or in confined spaces, the mechanical spindle can be used.

APPLICATION AREA

For particularly safe extraction of extremely tight and deep-seated bearings, gears and pulleys

BENEFIT

- Screwed connection enables easy loosening and particularly tight fastening of the jaws with an allen key
- The hydraulic spindle guarantees easy and controlled removal of particularly tight-fitting parts with minimal effort.
- In limited spatial conditions that require direct access to the component, the mechanical spindle can be used.
- The mechanical spindle has a rotating spindle tip for secure placement on smooth surfaces and during centering.
- Application also for eccentric components through freely movable, sliding puller jaws on the crossbar.
- Hexagonal profile on the crossbar for secure counterholding
- Variable adjustment to any spread between 3,2 mm – 160 mm
- Anti-shear suspension of the claw in the sliding piece (Armlock Technology)
- Optional convertible from an external puller to an internal extractor by reversing the jaws.
- Anti-slip safety at the spindle neck for safe working with a wrench.
- Spindle outlet for thread protection

OPERATION

- Position the puller jaws from the outside onto the part to be removed
- Slide the claws under the component
- Use a wrench to secure the jaws
- Engage the hexagon on the spindle head with a ratchet or a box wrench
- Reposition the hydraulic spindle until the component is loosened

MASTER DATA

GTIN [EAN]	4021176885808
Country of origin	DE
Case material	Tool steel
Series	20-Classic-B
Net weight [kg]	5,6 kg
Package contents	1 piece
Packaging Act	PAP 21
Global sales capability given	Yes (REACH, RoHS, POP, PROP65, TSCA)

SPARE PARTS

- 2-300-P_standard jaws

- 2-V-150-P_2 Puller jaw extensions (pair)
- 20-2-T_Crossbar for 20-2
- 620260_Two-sided spindle tip
- 621220_Mechanical pressure spindle
- 8-0-621_hydraulic spindle
- Hydraulic spindle

2-jaw universal puller with adjustable jaws, greased hydraulic spindle, up to 160 mm spread, 300 mm reach

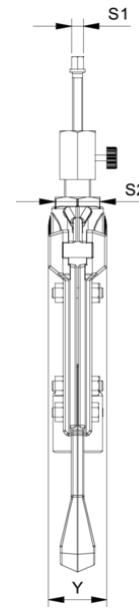
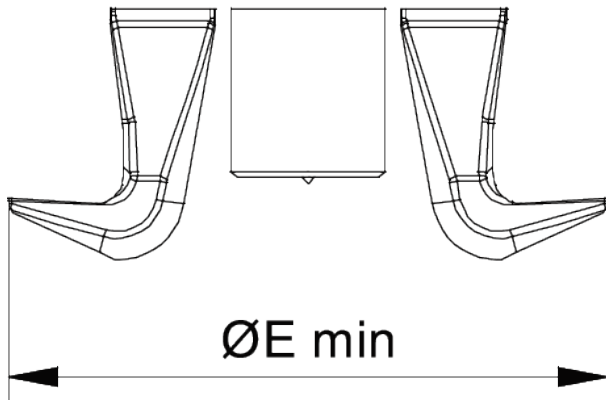

Abbreviation	Attribut	Wert
X	Total width [mm]	216 mm
Z	Total height [mm]	254 mm
A	Clamping depth outside pull-off [mm]	300 mm
S1	Width across flats [mm]	22 mm
S2	Width across flats [mm]	36 mm
Cmin	Span outside pull-off (min.) [mm]	3,2 mm
Cmax	Span outside pull-off (max.) [mm]	160 mm
K	Hook root thickness at the tip (claw thickness K) [mm]	4 mm
J	Hook base width (claw width J) [mm]	24 mm
O	Hook base depth usable (claw depth usable O) [mm]	18,4 mm
H	Total hook root depth (total claw depth H) [mm]	39,95 mm
L	Total claw thickness (L+1mm) (claw distance to base surface) [mm]	9 mm
Emin	Span inside pull-out (min.) [mm]	100 mm
Emax	Span inside pull-out (max.) [mm]	220 mm
Tmax	Max. torque [Nm]	15 Nm
Fmax	Max. tractive force [t]	10 t
Fmax	Max. tensile force [kN]	100 kN

Abbreviation	Attribut	Wert
X	Total width [mm]	216 mm
Z	Total height [mm]	254 mm
A	Clamping depth outside pull-off [mm]	300 mm
S1	Width across flats [mm]	22 mm
S2	Width across flats [mm]	36 mm
Cmin	Span outside pull-off (min.) [mm]	3,2 mm
Cmax	Span outside pull-off (max.) [mm]	160 mm
K	Hook root thickness at the tip (claw thickness K) [mm]	4 mm
J	Hook base width (claw width J) [mm]	24 mm
O	Hook base depth usable (claw depth usable O) [mm]	18,4 mm
H	Total hook root depth (total claw depth H) [mm]	39,95 mm
L	Total claw thickness (L+1mm) (claw distance to base surface) [mm]	9 mm
Emin	Span inside pull-out (min.) [mm]	100 mm
Emax	Span inside pull-out (max.) [mm]	220 mm
Tmax	Max. torque [Nm]	15 Nm
Fmax	Max. tractive force [t]	10 t
Fmax	Max. tensile force [kN]	100 kN

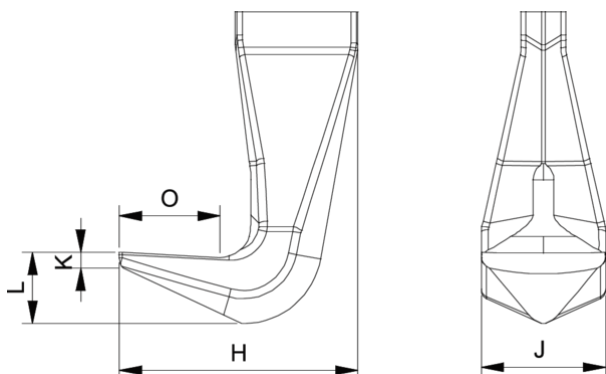

Abbreviation	Attribut	Wert
X	Total width [mm]	216 mm
Z	Total height [mm]	254 mm
A	Clamping depth outside pull-off [mm]	300 mm
S1	Width across flats [mm]	22 mm
S2	Width across flats [mm]	36 mm
Cmin	Span outside pull-off (min.) [mm]	3,2 mm
Cmax	Span outside pull-off (max.) [mm]	160 mm
K	Hook root thickness at the tip (claw thickness K) [mm]	4 mm
J	Hook base width (claw width J) [mm]	24 mm
O	Hook base depth usable (claw depth usable O) [mm]	18,4 mm
H	Total hook root depth (total claw depth H) [mm]	39,95 mm
L	Total claw thickness (L+1mm) (claw distance to base surface) [mm]	9 mm
Emin	Span inside pull-out (min.) [mm]	100 mm
Emax	Span inside pull-out (max.) [mm]	220 mm
Tmax	Max. torque [Nm]	15 Nm
Fmax	Max. tractive force [t]	10 t
Fmax	Max. tensile force [kN]	100 kN

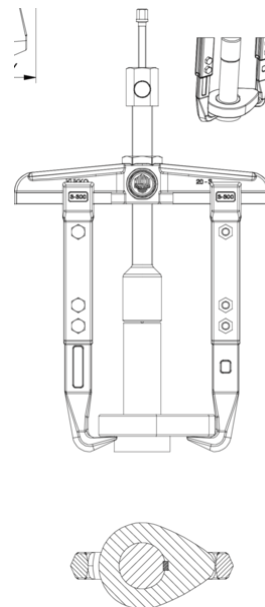

Abbreviation	Attribut	Wert
X	Total width [mm]	216 mm
Z	Total height [mm]	254 mm
A	Clamping depth outside pull-off [mm]	300 mm
S1	Width across flats [mm]	22 mm
S2	Width across flats [mm]	36 mm
Cmin	Span outside pull-off (min.) [mm]	3,2 mm
Cmax	Span outside pull-off (max.) [mm]	160 mm
K	Hook root thickness at the tip (claw thickness K) [mm]	4 mm
J	Hook base width (claw width J) [mm]	24 mm
O	Hook base depth usable (claw depth usable O) [mm]	18,4 mm
H	Total hook root depth (total claw depth H) [mm]	39,95 mm
L	Total claw thickness (L+1mm) (claw distance to base surface) [mm]	9 mm
Emin	Span inside pull-out (min.) [mm]	100 mm
Emax	Span inside pull-out (max.) [mm]	220 mm
Tmax	Max. torque [Nm]	15 Nm
Fmax	Max. tractive force [t]	10 t
Fmax	Max. tensile force [kN]	100 kN