

Roller Skates RS series

- ▲ Stable, rugged and low level construction.
- ▲ All maximum carrying capacities are based for use on a steel surface, which withstands the high pressure of the chain-rollers.
- ▲ The movement on tarmac and concrete is restricted. In these cases, a steel plate of a minimum of 10mm thickness is recommended.
- ▲ Moving speed not to exceed 5m/min.

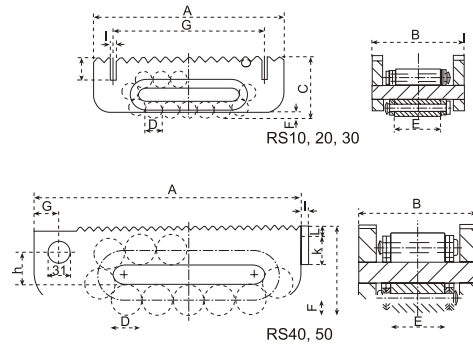
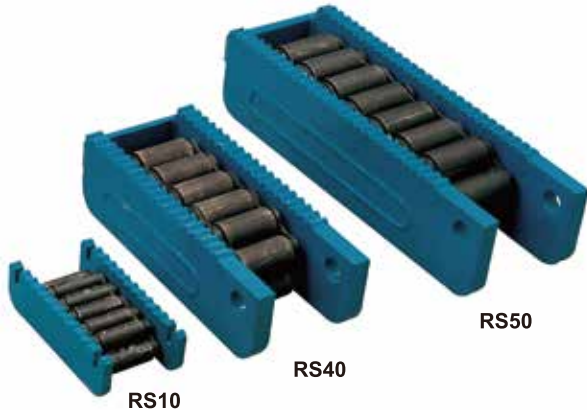

i-Lift No.		1911101	1911102	1911103	1911104	1911105
Model		RS10	RS20	RS30	RS40	RS50
A	(mm)(in.)	206(8.1)	216(8.5)	268(10.6)	380(15)	530(120.9)
B	(mm)(in.)	100(4)	112(4.4)	127(5)	168(6.6)	182(7.2)
C	(mm)(in.)	67(2.6)	74(2.9)	91(3.6)	125(5)	145(5.7)
D	(mm)(in.)	18(0.7)	24(0.9)	30(1.2)	42(1.6)	50(2)
E	(mm)(in.)	51(2)	58(2.2)	66(2.6)	76(3)	86(3.3)
F	(mm)(in.)	7(0.3)	11(0.4)	13(0.5)	16(0.6)	19(0.7)
G	(mm)(in.)	166(6.5)	178(7)	218(8.5)		36(1.4)
H	(mm)(in.)		—		48(1.9)	60(2.4)
I	(mm)(in.)		8(0.3)			10(0.4)
K	(mm)(in.)		26(1)			40(1.5)
L	(mm)(in.)		—			15(0.6)
Rollers under stress		5		4		6
Number of Rollers		15		13		17
Capacity	kg(lb.)	10000(22000)	15000(33000)	30000(66000)	60000(132000)	80000(176000)
Wt.	kg(lb.)	5.2(11.4)	7.4(16)	13(28.6)	32(70.4)	61(134.2)

Complete Skate Kits SK

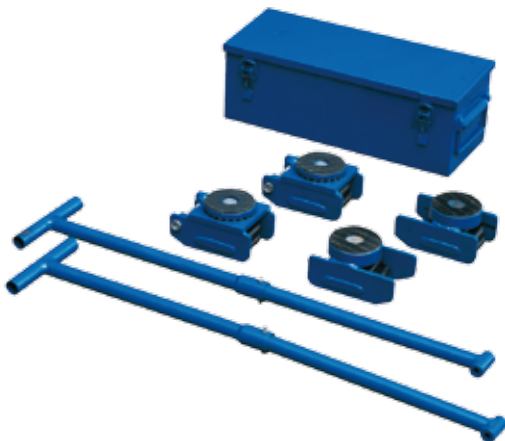

Include four roller skates, two steering handles, one box.

i-Lift No.		1911201
Model		SK04
Capacity	kg(lb.)	4000(8800)
Dimensions of Roller Skate	LxWxH (mm)(in.)	154x102x90(6x4x3.5)
Swivel Top	(mm)(in.)	Φ90(3.5)
Dimensions of Roller	(mm)(in.)	Φ18x51(1x2)
Length of Handle Bar	(mm)(in.)	850(33.5)
Dimensions of the box	LxWxH (mm)(in.)	470x180x160(18.5x7x6.3)
Weight of kit	kg(lb.)	24(52.8)