

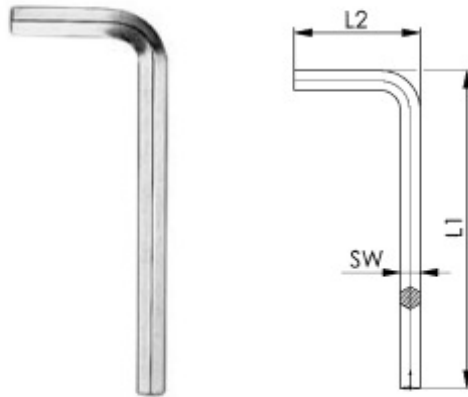

## ISO 2936D

### Hexagon keys (metric)

CHROM VANADIUM, hardened and **nickel-plated**.  
End face machined. Edges of end face chamfered.



Order no.	SW [mm]	SW [inch]	L1 x L2 [mm]	Weight [g]
43299	1,3	0,05	41 x 13	0,7
42630	1,5	-	46,5 x 15,5	0,9
42648	2,0	5/64*	52,0 x 18,0	1,8
42655	2,5	-	58,5 x 20,5	3,0
42663	3,0	-	66 x 23	5,0
42671	4,0	5/32*	74 x 29	10
42689	5,0	-	85 x 33	18
42697	6,0	-	96 x 38	30
42705	7,0	9/32*	102 x 41	43
42713	8,0	5/16*	108 x 44	59
42721	9,0	-	114 x 47	79
42739	10,0	-	122 x 50	103
42747	11,0	7/16*	129 x 53	131
42754	12,0	-	137 x 57	160
42762	14,0	-	154 x 70	260
42770	17,0	-	177 x 80	430
42788	19,0	3/4*	199 x 89	617
42796	22,0	7/8*	222 x 102	920

The 1.3 A/F key is in fact 1.27 mm, which is precisely 0.05".

Keys marked \* correspond to the metric size. Above 5/32" A/F they are marked with both sizes.

### On request:

Other lengths and executions on request.